



THE DISTRICT COUNCIL OF MOKA

Ref.: W/OAB/03/2016

STANDARD BIDDING DOCUMENTS

for

CONSTRUCTION OF DRAIN NETWORK TO RIVULET DICKSON IN VICINITY OF BOODHOOA ROAD AND SCHOOL ROAD AT DAGOTIERE

*District Council Office
Royal Road
QUARTIER MILITAIRE*

Tel : 435 5531
Fax.: 435 5685

18 May 2016

AMENDMENTS TO DOCUMENT DATED 17 OCTOBER 2013
AMENDMENTS TO DOCUMENT DATED 30 APRIL 2015

PART 1: Section I **Instruction to Bidders**
Sub-clause 5 (Amended)

AMENDMENTS TO DOCUMENT DATED 27 NOVEMBER 2014

PART 1: Section I **Instruction to Bidders**
Sub-clause 5 (Amended)
Clause 6 (Amended)

Section II: **Bidding Data Sheet**
ITB 6.4(a) and 6.4(b) (Added)

Section III: **Bidding Forms**
Qualification Information (Amended)

AMENDMENTS TO DOCUMENT DATED 06 MAY 2014

PART 1: Section I **Instruction to Bidders**
Sub-clause 5.1 (Amended)
Sub-clause 6.2(g) (Amended)

Section II: **Bidding Data Sheet**
ITB 40.3 (Amended)

Section III: **Bidding Forms**
Qualification Information (Amended)

AMENDMENTS TO DOCUMENT DATED 25 FEBRUARY 2014

PART 1: Section II: **Bidding Data Sheet**
ITB 3.2 (b) (Amended)

Section III: **Bidding Forms**
Paragraph (l) (Added) and Paragraph (m) (Amended)

AMENDMENTS TO DOCUMENT DATED 17 OCTOBER 2013

PART 1: Section I **Instruction to Bidders**
Clause 4.4 (Added)

Section III: **Bidding Forms**
Bid Submission Form (Amended)

AMENDMENTS TO DOCUMENT DATED 04 JUNE 2013

PART 1: Section I **Instruction to Bidders**
Sub-clause 6.2 (f) (Amended)

Section III: **Bidding Forms**
Qualification information (**Amended**)

AMENDMENTS TO DOCUMENT DATED 26 DECEMBER 2012

PART 1: Section I **Instruction to Bidders**
Sub-clause 38.3 (**Deleted**)
Sub-clause 40.3 (**Added**)
Sub-clause 43.1 (**Added**)

Section II: **Bidding Data Sheet**
ITB 32.1 (**Amended**)
ITB 32.2 (**Amended**)
ITB 40.3 (**Added**)

Section III: **Bidding Forms**
Bid Submission Form (**Amended**)

Section IV: **Evaluation Criteria**
Sub-clause (e) (**Amended**)

PART 3 Section VIII **Contract Forms**
Form of Preference Security (**Added**)

AMENDMENTS TO DOCUMENT DATED 11 OCTOBER 2012

PART 1: Section I **Instruction to Bidders**
Sub-clause 6.2(f) (**Amended**)

AMENDMENTS TO DOCUMENT DATED 27 JULY 2012

PART 1: Section I **Instruction to Bidders**
Sub-clause 5.3 (**Amended**)
Sub-clause 6.2(d) (**Deleted**)
Sub-clause 13.1 (e) (**Deleted**)
Sub-clause 21.2 (**Added**)

Section II **Bidding Data Sheet**
ITB 6.2 (b) (**Deleted**)

AMENDMENTS TO DOCUMENT DATED 26 APRIL 2012

PART 1: Section II **Bidding Data Sheet**
ITB 6.3 (a) (**Amended**)

AMENDMENTS TO DOCUMENT DATED 20 MARCH 2012

PART 1: Section III: **Bidding Forms**
Bid Submission Form (**Amended**)

AMENDMENTS TO DOCUMENT DATED 19 APRIL 2011

PART I: Section I: **Instruction to Bidders**
Sub-clause 38.1 (Amended)

AMENDMENTS TO DOCUMENT DATED 23 MARCH 2011

PART I: Section IV: **Evaluation Criteria**
Sub-clause 1.2.1 (a) (Amended)

AMENDMENTS TO DOCUMENT DATED 11 OCTOBER 2011

PART I: Section I: **Instruction to Bidders**

Sub-clause 2.1 (Added)
Sub-clause 30.2 (deleted)
Sub-clause 31 (Amended)
Sub-Clause 37 (Amended)

Section II: **Bidding Data Sheet**
ITB 2.1 (Added)
ITB 31 (Amended)

Section IV: **Evaluation Criteria**
Paragraph 1(e) (Added)

AMENDMENTS TO DOCUMENT DATED 26 MAY 2010

PART I: Section II: **Bidding Data Sheet**
ITB 31.1 (Amended)

Foreword

The Standard Bidding Documents in this publication follow the Standard Bidding Documents of the World Bank and have been prepared pursuant to section 7(c) of the Public Procurement Act 2006 for use by public bodies for procurement of works for values up to 100 million rupees. These documents may be used for national Open Advertised Bidding (OAB) and Restricted Biding. They assume that no pre-qualification has taken place before bidding.

Those wishing to submit comments or suggestions on the Bidding Documents or to obtain additional information on procurement in Mauritius are encouraged to contact:

**The Director
Procurement Policy Office
Ministry of Finance and Economic Development
Level 8, Emmanuel Anquetil Building, Port Louis, Mauritius
Tel: No. (230)201-3760 & Fax: No. (230)201-3758
Email: mof-pposecretariat@govmu.org**

Preface

This document has been adapted from the Standard Bidding Document issued by the Procurement Office Ref. W/SBD21/01-09 for works up to the value of Rs. 400m. It can be used in the award of admeasurement (unit prices or unit rates in a bill of quantities) and lump sum types of contracts, which are the most common in Works contracting.

Lump sum contracts are used in particular for buildings and other forms of construction where the Works are well defined and are unlikely to change in quantity or specification, and where encountering difficult or unforeseen site conditions (for example, hidden foundation problems) is unlikely. Lump sum contracts should be used for Works that can be defined in their full physical and qualitative characteristics before bids are called, or where the risks of substantial design variations are minimal. In lump sum contracts, the concept of priced “Activity Schedule” is used, to enable payments to be made on the basis of percentage completion of each activity.

This document is recommended for works values of up to Rs. 100m. However, in specific circumstances it may be used for values slightly higher with the approval of the Procurement Policy Office.

Summary Description

This Standard Bidding Document for Procurement of Works is to be used when a prequalification process has not taken place before bidding and, therefore, post-qualification applies. A brief description of these documents is given below.

SBD for Procurement of Works

PART 1 – BIDDING PROCEDURES

Section I. Instructions to Bidders (ITB)

This Section provides relevant information to help Bidders prepare their bids. Information is also provided on the submission, opening, and evaluation of bids and on the award of Contracts. **Section I contains provisions that are to be used without modification.**

Section II. Bidding Data Sheet

This Section consists of provisions that are specific to each procurement and that supplement the information or requirements included in Section I, Instructions to Bidders.

Section III. Bidding Forms

This Section contains the forms which are to be completed by the Bidder and submitted as part of his Bid.

Section IV. Evaluation Criteria

This section contains supplementary evaluation criteria which the Employer may choose to apply to the procurement under consideration.

PART 2 – EMPLOYER’S REQUIREMENTS

Section V. Employer’s Requirements

This Section contains the Specification, the Drawings, and supplementary information that describe the Plant and Installation Services to be procured.

PART 3 – CONDITIONS OF CONTRACT AND CONTRACT FORMS

Section VI. General Conditions of Contract

This Section contains the general clauses to be applied in all contracts. **The text of the clauses in this Section shall not be modified.**

Section VII. Particular Conditions of Contract

The contents of this Section supplement the General Conditions of Contract and shall be prepared by the Employer.

Section VIII. Contract Forms

This Section contains forms which, once completed, will form part of the Contract. The forms for **Performance Security** and **Advance Payment Security**, when required, shall only be completed by the successful Bidder after contract award.

BIDDING DOCUMENTS

for

Procurement of for the

**Construction of Drain Network to
Rivulet Dickson in vicinity of
Boodhooa Road and School Road at
Dagotiere**

Procurement Reference No: W/OAB/03/2016

The District Council of Moka

Standard Bidding Document

Table of Contents

PART 1 – Bidding Procedures.....	1
Section 1 - Instructions to Bidders	2
Section II- Bidding Data Sheet	20
Section III - Bidding Forms	24
Section IV - Evaluation Criteria.....	36
PART 2 – Employer’s Requirements	38
Section V - Employer’s Requirements	39
PART 3 – Conditions of Contract and Contract Forms	44
Section VI. General Conditions of Contract.....	45
Section VII. Particular Conditions of Contract.....	46
Section VIII - Contract Forms	50

PART 1 – Bidding Procedures

Section 1 - Instructions to Bidders

Table of Contents

A.	General.....	4
1.	Scope of Bid.....	4
2.	Source of Fund.....	4
3.	Challenge and Appeal.....	4
4.	Fraud and Corruption.....	4
5.	Eligible Bidders.....	6
6.	Qualifications of Bidders.....	8
B.	Contents of Bidding Document.....	11
7.	Sections of Bidding Document.....	11
8.	Clarification of Bidding Document.....	11
9.	Site visit/Pre-bid meeting.....	11
10.	Amendment of Bidding Document.....	11
C.	Preparation of Bids.....	12
11.	Cost of Bidding.....	12
12.	Language of Bid.....	12
13.	Documents Comprising the Bid.....	12
14.	Bid Submission Form and Schedules.....	12
15.	Alternative Proposal.....	12
16.	Bid Prices and Discounts.....	12
17.	Currencies of Bid and Payment.....	13
18.	Documents Comprising the Technical Proposal.....	13
19.	Period of Validity of Bids.....	13
20.	Bid Security/Bid Securing Declaration.....	13
21.	Format and Signing of Bid.....	14
D.	Submission and Opening of Bids.....	14
22.	Sealing and Marking of Bids.....	14
23.	Deadline for Submission of Bids.....	14
24.	Late Bids.....	15
25.	Withdrawal, Substitution, and Modification of Bids.....	15
26.	Bid Opening.....	15
E.	Evaluation and Comparison of Bids.....	15
27.	Confidentiality.....	15
28.	Clarification of Bids.....	15
29.	Determination of Responsiveness.....	15
30.	Nonconformities, Errors, and Omissions.....	16

31.	Correction of Arithmetical Errors.....	16
32.	Margin of Preference	16
33.	Evaluation of Bids	16
34.	Comparison of Bids	17
35.	Qualification of the Bidder.....	17
36.	Employer’s Right to Accept Any Bid, and to Reject Any or All Bids	17
F.	Award of Contract	17
37.	Award Criteria	17
38.	Notification of Award.....	17
39.	Signing of Contract.....	18
40.	Performance Security.....	18
	Preference Security.....	19
41.	Advance Payment and Security.....	19
42.	Plant and Materials on site	19
43.	Debriefing	19

Section I - Instructions to Bidders

A. General

1. **Scope of Bid**
 - 1.1 The Public Body as defined¹ in Section II “Bidding Data Sheet” (**BDS**) also referred to herein as Employer invites bids for the construction of Works, as **described in the BDS** and Section VII, “Particular Conditions of Contract” (PCC).

The name and identification number of the Contract are **provided in the BDS and the PCC**.
 - 1.2 The successful Bidder shall be expected to complete the Works by the Intended Completion Period **specified in the BDS**.
 - 1.3 Throughout these bidding documents, the terms:
 - (a) “writing” means any typewritten or printed communication, including e-mail and facsimile transmission,
 - (b) “day” means calendar day, and
 - (c) Singular also means plural.
2. **Source of Fund**
 - 2.1 The Works shall be financed by the Public Body’s own budgetary allocation, **unless otherwise stated in the BDS**.
3. **Challenge and Appeal**
 - 3.1 Unsatisfied bidders shall follow procedures prescribed in Regulations 48, 49 and 50 of the Public Procurement Regulations 2008 to challenge procurement proceedings and award of procurement contracts or to file application for review at the Independent Review Panel.
 - 3.2 Addresses to forward Challenges or Application for Review are **specified in the BDS**.
4. **Fraud and Corruption**
 - 4.1 The Government of the Republic of Mauritius requires that bidders/suppliers/contractors, participating in procurement in Mauritius, observe the highest standard of ethics during the procurement process and execution of contracts.
 - 4.2 Bidders, suppliers and public officials shall be aware of the provisions stated in sections 51 and 52 of the Public Procurement Act which can be consulted on the website of the Procurement Policy Office (PPO): ppo.govmu.org

¹ See Section IV, “General Conditions of Contract,” Clause 1. Definitions.

- 4.3 The Employer will reject a proposal for award if it determines that the Bidder recommended for award has, directly or through an agent, engaged in corrupt, fraudulent, collusive, coercive or obstructive practices in competing for the contract in question;

For the purposes of this Sub-Clause:

- (i) “corrupt practice” is the offering, giving, receiving or soliciting, directly or indirectly, of anything of value to influence improperly the actions of another party;
 - (ii) “fraudulent practice” is any act or omission, including a misrepresentation, that knowingly or recklessly misleads, or attempts to mislead, a party to obtain a financial or other benefit or to avoid an obligation;
 - (iii) “collusive practice” is an arrangement between two or more parties designed to achieve an improper purpose, including to influence improperly the actions of another party;
 - (iv) “coercive practice” is impairing or harming, or threatening to impair or harm, directly or indirectly, any party or the property of the party to influence improperly the actions of a party;
 - (v) “obstructive practice” is deliberately destroying, falsifying, altering or concealing of evidence material to the investigation or making false statements to investigators in order to materially impede an investigation into allegations of a corrupt, fraudulent, coercive or collusive practice; and/or threatening, harassing or intimidating any party to prevent it from disclosing its knowledge of matters relevant to the investigation or from pursuing the investigation
- 4.4 The Employer commits itself to take all measures necessary to prevent fraud and corruption and ensures that none of its staff, personally or through his/her close relatives or through a third party, will in connection with the bid for, or the execution of a contract, demand, take a promise for or accept, for him/herself or third person, any material or immaterial benefit which he/she is not legally entitled to. If the Employer obtains information on the conduct of any of its employees which is a criminal offence under the relevant Anti-Corruption Laws of Mauritius or if there be a substantive suspicion in this regard, he will inform the relevant authority (ies) and in addition can initiate disciplinary actions. Furthermore, such bid shall be rejected.

5. Eligible Bidders 5.1

(a) In accordance with CIDB (Registration of Consultant and Contractors) Regulation 2014, Contractors currently operating in the construction industry have the statutory obligation to be registered with the Construction Industry Development Board (CIDB) accordingly.

(b) Subject to paragraph (c) below, a transition period as from 01 August 2014 is provided for all contractors to register with the CIDB.

(c) Foreign contractors as defined in the CIDB Act will have to apply for and obtain a Provisional Registration prior to bidding for this project. If the contract is awarded to the foreign contractor the latter shall have to apply for and obtain a Temporary Registration before starting the project.

(d) Contractors whether local or foreign under an existing or intended joint venture will be eligible as a joint venture if, in addition to their respective individual registration, they obtain a Provisional Registration for the joint venture prior to bidding for this project. If an existing or intended joint venture is awarded the contract it shall have to apply for a Temporary Registration prior to starting the project.

(e) Sub-contractors undertaking works for value Rs 500 000 or above are subject to registration as applicable to Contractors.

(f) Notwithstanding paragraphs (a) and (c) above, a firm or person that was undertaking construction works, in Mauritius immediately before 1 August 2014 may continue to undertake construction works for such period as may be prescribed, without being registered as a contractor or foreign contractor, as the case may be. They may thus participate in public procurement and be awarded a public contract during that period.

(g) Bidders may consult the website of the CIDB cidb.govmu.org for further details concerning registration of contractors.

5.2 (a) Bidder may be natural person, private entity, or government-owned entity or any combination of them in the form of a joint venture.

(b) Bids submitted by a joint venture of two or more firms as partners shall comply with the following requirements, unless otherwise stated in the **BDS**:

(i) the Bid shall include all the information listed in ITB Sub-Clause 6.2 below for each joint venture partner;

- (ii) the Bid shall be signed so as to be legally binding on all partners;
 - (iii) the Bid shall include a copy of the agreement entered into by the joint venture partners defining the division of assignments to each partner and establishing that all partners shall be jointly and severally liable for the execution of the Contract in accordance with the Contract terms; alternatively, a Letter of Intent to execute a joint venture agreement in the event of a successful bid shall be signed by all partners and submitted with the bid, together with a copy of the proposed agreement;
 - (iv) one of the partners shall be nominated as being in charge, authorized to incur liabilities, and receive instructions for and on behalf of any and all partners of the joint venture; and
 - (v) the execution of the entire Contract, including payment, shall be done exclusively with the partner in charge.
- 5.3 A Bidder shall not have a conflict of interest. All Bidders found to have a conflict of interest shall be disqualified. A Bidder may be considered to have a conflict of interest with one or more parties in this bidding process, if :
- (a) they have a controlling partner in common; or
 - (b) they receive or have received any direct or indirect subsidy from any of them; or
 - (c) they have the same legal representative for purposes of this bid; or
 - (d) they have a relationship with each other, directly or through common third parties, that puts them in a position to have access to information about or influence on the Bid of another Bidder, or influence the decisions of the Employer regarding this bidding process; or
 - (e) a Bidder participates in more than one bid in this bidding process. Participation by a Bidder in more than one Bid will result in the disqualification of all Bids in which the party is involved. However, this does not limit the inclusion of the same subcontractor in more than one bid; or
 - (f) a Bidder or any of its affiliates participated as a consultant in the preparation of the design or technical

specifications of the contract that is the subject of the Bid; or

- (g) a Bidder, or any of its affiliates has been hired (or is proposed to be hired) by the Employer as Engineer for the contract.

5.4 (a) A bidder that is under a declaration of ineligibility by the Government of Mauritius in accordance with applicable laws at the date of the deadline for bid submission and thereafter shall be disqualified

- (b) Bids from contractors appearing on the ineligibility lists of African Development Bank, Asian Development Bank, European Bank for Reconstruction and Development, Inter-American Development Bank Group and World Bank Group shall be rejected.

Links for checking the ineligibility lists are available on the PPO's website: ppo.govmu.org

5.5 Government-owned enterprises in the Republic of Mauritius shall be eligible only if they can establish that they are legally and financially autonomous and operate under commercial law, and that they are not a dependent agency of the Government.

6. Qualifications of Bidders

6.1 All bidders shall provide in Section III, a preliminary description of the proposed work method and schedule, including drawings and charts, as necessary.

6.2 Bidders shall include the information and documents listed hereunder with their bids, unless otherwise **stated in the BDS subject to ITB sub-clause 6.3**. If, after opening of bids, it is found that any document is missing, the Employer may request the submission of that document subject to clause 30. The non-submission of the documents by the Bidder within the prescribed period may lead to the rejection of its bid.

- (a) copies of original documents defining the constitution or legal status, place of registration, and principal place of business of the Bidder;
- (b) total monetary value of construction works performed for each of the last five years;
- (c) experience in works of a similar nature and size for each of the last five years or as otherwise **stated in the BDS**; and clients who may be contacted for further information on those contracts;
- (d) major items of construction equipment proposed to carry out the Contract;
- (e) qualifications and experience of key site personnel and

technical personnel proposed for the contract;

- (f) report on the financial standing of the Bidder for the last three years, such as certified copies of Financial Statements/Audited Accounts as filed at the Registrar of Companies before the deadline set for submission of bids;
- (g) evidence of adequacy of cash-flow capital for this Contract (access to line(s) of credit and availability of other financial resources);
- (h) authority to seek references from the Bidder's bankers;
- (i) information regarding any litigation, current or during the last five years, in which the Bidder was/is involved, the parties concerned, the issues involved, the disputed amounts, and awards; and
- (j) proposals for subcontracting components of the Works amounting to more than 10 percent of the Contract Price

- 6.3 The ITB sub-clauses 6.2 (b), (c), and (f) shall not apply for bidders having a Provisional Registration or bidders currently operating in Mauritius who are duly registered with the CIDB under the grade that covers adequately the size and type of works related to the project.
- 6.4 To qualify for award of the Contract, bidders shall meet the following minimum qualifying criteria **subject to ITB sub-clause 6.5**:
- a) a minimum average annual financial amount of construction work over the period **or registered with the CIDB under the grade specified in the BDS.**
 - (b) experience as prime contractor in the construction of a minimum number of works of a nature and complexity equivalent to the Works over a period (To comply with this requirement, works cited should be at least 70 percent complete) **or registered with the CIDB under field of specialisation specified in the BDS ;**
 - (c) proposals for the timely acquisition (own, lease, hire, etc.) of the essential equipment **listed in the BDS;**
 - (d) a Contract Manager/Supervisor with five years' experience in works of an equivalent nature and volume, including no less than three years as Manager or as otherwise **specified in the BDS;** and
 - (e) liquid assets and/or credit facilities, net of other contractual commitments and exclusive of any advance payments which may be made under the Contract, of no less than the amount **specified in the BDS.**²

A consistent history of litigation or arbitration awards against the Applicant or any partner of a Joint Venture may result in Disqualification.

- 6.5 ITB sub-clause 6.4 (a) shall not apply to bidders having a Provisional Registration or bidders currently operating in Mauritius who are duly registered with the CIDB under the grade that covers adequately the size and type of works related to the project.

ITB sub-clause 6.4 (b) shall not apply where the category of field of specialization as defined by CIDB referred to in the BDS covers adequately the field of specialization in respect of the complexity and key specialization defined by the public body.

² Usually the equivalent of the estimated payments flow over 4-6 months at the average (straight line distribution) construction rate. The actual period of reference shall depend on the speed with which the Government shall pay the Contractor's monthly certificates.

B. Contents of Bidding Document

- 7. Sections of Bidding Document**
- 7.1 The Bidding Document consists of all the Sections indicated below, and should be read in conjunction with any Addenda issued in accordance with ITB 10.
- Section I - Instructions to Bidders (ITB)
 - Section II- Bidding Data Sheet
 - Section III - Bidding Forms
 - Section IV - Evaluation Criteria
 - Section V - Employer's Requirements
 - Section VI – General Conditions of Contract
 - Section VII- Particular Conditions of Contract
 - Section VIII - Contract Forms
- 7.2 The Invitation for Bids issued by the Employer is not part of the Bidding Document.
- 8. Clarification of Bidding Document**
- 8.1 A prospective Bidder requiring any clarification of the Bidding Document shall contact the Employer in writing at the Employer's address **indicated in the BDS**.
- The Employer will respond in writing to any request for clarification, provided that such request is received 15 days prior to the deadline for submission of bids.
- Should the Employer deem it necessary to amend the Bidding Document as a result of a request for clarification, it shall do so following the procedure under ITB 10.
- 9. Site visit/Pre-bid meeting**
- 9.1 Bidders, at the Bidders' own responsibility and risk, are encouraged to visit and examine the Site of Works and its surroundings and obtain all information that may be necessary for preparing their Bids and entering into a contract for construction of the Works. The costs of visiting the Site shall be at the Bidders' own expense.
- 9.2 The Bidder or its designated representative is invited to attend a pre-bid meeting, as **provided for in the BDS**. The purpose of the pre-bid meeting will be to clarify issues and to answer questions on any matter that may be raised at that stage.
- Non-attendance at the pre-bid meeting will not be a cause for disqualification of a bidder.
- 10. Amendment of Bidding**
- At any time prior to the deadline for submission of bids, the Employer may amend the Bidding Document by issuing addenda and extend the deadline for submission of bids, if

Document needed.

C. Preparation of Bids

- 11. Cost of Bidding** 11.1 The Bidder shall bear all costs associated with the preparation and submission of its Bid, and the Employer shall in no case be responsible or liable for those costs irrespective of the outcome of the bidding process.
- 12. Language of Bid** 12.1 The Bid, supporting documents as well as all correspondence relating to the bid exchanged by the Bidder and the Employer shall be in English Language.
- 13. Documents Comprising the Bid** 13.1 The Bid shall comprise the following:
- (a) Bid submission Form (in the format indicated in Section III);
 - (b) Qualification information and documentary evidence establishing the Bidder's qualifications to perform the contract;
 - (c) completed Bill of Quantities / Activity Schedule;
 - (d) Bid Security as per the format provided in section III or as a subscription to a Bid Securing Declaration in the Bid Submission Form;
- and any other material required to be completed and submitted by bidders, as specified in ITB **and the BDS**.
- 14. Bid Submission Form and Schedules** 14.1 The Bid Submission Form, Schedules, and all documents listed under ITB 13.1 shall be prepared using the relevant forms, if so provided.
- 15. Alternative Proposal** 15.1 Alternative Technical Proposals and completion dates if allowed shall be indicated in Section V- Specifications. The evaluation methodologies for their consideration shall be given in Section IV.
- 16. Bid Prices and Discounts** 16.1 The Contract shall be for the whole Works, as described in ITB Sub-Clause 1.1, based on the priced Activity Schedule/Bill of Quantities³ submitted by the Bidder.
- 16.2 Bidders shall fill in rates and prices for all items of the Works described in the Bill of Quantities.⁴ Items for which no rate or price is entered by Bidders, shall not be paid for by the Public Body when executed and shall be deemed covered by the other rates and prices in the Bill of Quantities. Corrections, if any, shall be made by crossing out, initialing,

³ In lump sum contracts, delete "priced Bill of Quantities" and replace with "priced Activity Schedule."

⁴ In lump sum contracts, delete "described in the Bill of Quantities" and replace with "described in the drawings and specifications and listed in the Activity Schedule."

dating and rewriting.

16.3 All duties, taxes, and other levies payable by the Contractor under the Contract, or for any other cause, as of the date 14 days prior to the deadline for submission of bids, shall be included in the rates, prices, and total Bid price submitted by Bidders.⁵

16.4 The price to be quoted in the Bid Submission Form shall be the total price of bid after any discount offered.

The discount if any and the conditions of its application shall be indicated separately.

17. Currencies of Bid and Payment

17.1 The bid price and rates shall be in Mauritian Rupees and fixed for the duration of the contract unless otherwise **specified in the BDS.**

17.2 Unless otherwise **specified in BDS** interim payment for Plant and Material on site is applicable as per GCC 39.7.

18. Documents Comprising the Technical Proposal

18.1 The Bidder shall furnish a Technical Proposal including a statement of work methods, equipment, personnel, schedule and any other information as stipulated in the Bidder Qualification Form (section III), in sufficient details to demonstrate the adequacy of the Bidders' proposal to meet the work requirements and the completion time.

19. Period of Validity of Bids

19.1 Bids shall remain valid for a period of 90 days after the bid submission deadline prescribed by the Employer unless otherwise **specified in the BDS.**

19.2 In exceptional circumstances, prior to expiry of the original bid validity period, the Employer may request that the bidders extend the period of validity for a specified additional period. The request and the responses thereto shall be made in writing.

20. Bid Security/Bid Securing Declaration

20.1 The Bidder shall furnish either a subscription to a Bid Securing Declaration or a Bid Security in its original form with its bid as part of its bid, if so **required in the BDS.**

20.2 Bid Security shall be in the form of a Bank Guarantee from a local commercial bank as per the format contained in section III and shall be valid for a period of 30 days beyond the validity period of the bid or beyond any period of extension.

20.3 Any bid not accompanied by an enforceable and substantially compliant Bid Security or a subscription to a Bid Securing Declaration in the Bid Submission Form, if required in accordance with ITB 20.1, shall be rejected by the Employer

⁵ *In lump sum contracts, delete "rates, prices, and."*

as non-responsive.

20.4 Bid Security shall be forfeited or the Bid Securing declaration exercised for non-compliance on the part of the Bidder for reasons mentioned in the Bid Security format contained in Section III or the Bid Suring Declaration contained as Appendix to the Bid Submission Form.

21. Format and Signing of Bid

21.1 The Bidder shall prepare one original of the documents comprising the bid as described in ITB 13.1 and clearly mark it "ORIGINAL". In addition, the Bidder shall submit **two copies** of the bid and clearly mark each of them "COPY." In the event of any discrepancy between the original and the copies, the original shall prevail.

21.2 The original and all copies of the bid shall be typed or written in indelible ink and shall be signed by a person duly authorized to sign on behalf of the Bidder.

D. Submission and Opening of Bids

22. Sealing and Marking of Bids

22.1 Bidders may always submit their bids by mail or by hand. Procedures for submission, sealing and marking are as follows:

(a) Bidders submitting bids by mail or by hand shall enclose the original and each copy of the Bid, including alternative bids, if permitted in accordance with ITB 15, in separate sealed envelopes, duly marking the envelopes as "ORIGINAL", "ALTERNATIVE" and "COPY." These envelopes containing the original and the copies shall then be enclosed in one single envelope. The rest of the procedure shall be in accordance with ITB sub-Clauses 22.2.

22.2 The inner and outer envelopes shall:

- (a) bear the name and address of the Bidder;
- (b) be addressed to the Employer as indicated in ITB 22.1;
- (c) bear the specific identification of this bidding process indicated in accordance with ITB 1.1; and
- (d) bear a warning not to open before the time and date for bid opening.

23. Deadline for Submission of Bids

23.1 Bids shall be delivered to the Employer at the address and no later than the time and date **specified in the BDS**.

The Employer may, at its discretion, extend the deadline for the submission of bids by amending the Bidding Document in

accordance with ITB 10.

- 24. Late Bids** 24.1 Late bids shall not be considered. They will be returned unopened
- 25. Withdrawal, Substitution, and Modification of Bids** 25.1 No bid may be withdrawn, substituted, or modified in the interval between the deadline for submission of bids and the expiration of the period of bid validity specified by the Bidder on the Bid submission Form or any extension thereof.
- 26. Bid Opening** 26.1 The Employer shall open the bids at the time place and address **specified in the BDS** in the presence of Bidders' designated representatives who choose to attend.
- 26.2 The bidders' names, the Bid Prices, the total amount of each bid, any discounts, any alternative bid, bid modifications and withdrawals, the presence or absence of bid security, and such other details as the Employer may consider appropriate, will be announced and recorded by the Employer at the opening.

E. Evaluation and Comparison of Bids

- 27. Confidentiality** 27.1 Information relating to the examination, evaluation, comparison, and post-qualification of bids and recommendation of contract award, shall not be disclosed to Bidders or any other person not officially concerned with such process.
- 27.2 Any attempt by a Bidder to influence the Employer in the evaluation of the bids or Contract award decisions may result in the rejection of its bid.
- 28. Clarification of Bids** 28.1 To assist in the examination, evaluation, and comparison of the bids, and qualification of the Bidders, the Employer may, at its discretion, ask any Bidder for a clarification of its bid. No change in the prices or substance of the bid shall be sought, offered, or permitted, except to confirm the correction of arithmetical errors discovered by the Employer in the evaluation of the bids, in accordance with ITB 31.
- 29. Determination of Responsiveness** 29.1 The Employer's determination of a bid's responsiveness is to be based on the contents of the bid itself, as defined in ITB13.
- 29.2 A substantially responsive bid is one that meets the requirements of the Bidding Document without material deviation, reservation, or omission.
- 29.3 The Employer shall examine the technical aspects of the bid submitted in accordance with ITB 18, Technical Proposal, in particular, to confirm that all requirements of Section IV

(Employer's Requirements) have been met without any material deviation, reservation or omission.

29.4 If a bid is not substantially responsive to the requirements of the Bidding Document, it shall be rejected by the Employer and may not subsequently be made responsive by correction of the material deviation, reservation, or omission.

30. Nonconformities, Errors, and Omissions

30.1 Provided that a bid is substantially responsive, the Employer may waive any non-material non-conformity in the bid, request that the Bidder submit the necessary information or documentation, to rectify nonmaterial nonconformities in the bid related to documentation requirements but not related to any aspect of the price of the bid; and shall rectify quantifiable nonmaterial nonconformities related to the Bid Price.

31. Correction of Arithmetical Errors

31.1 Provided that the bid is substantially responsive, the Employer shall correct arithmetical errors on the following basis:

- (a) only for unit price contracts, if there is a discrepancy between the unit price and the total price that is obtained by multiplying the unit price and quantity, the unit price shall prevail and the total price shall be corrected, unless in the opinion of the Employer there is an obvious misplacement of the decimal point in the unit price, in which case the total price as quoted shall govern and the unit price shall be corrected;
- (b) if there is an error in a total corresponding to the addition or subtraction of subtotals, the subtotals shall prevail and the total shall be corrected; and
- (c) if there is a discrepancy between words and figures, the amount in words shall prevail, unless the amount expressed in words is related to an arithmetic error, in which case the amount in figures shall prevail subject to (a) and (b) above.

32. Margin of Preference

32.1 **Unless otherwise specified in the BDS,** Margin of preference shall not apply.

33. Evaluation of Bids

33.1 The Employer shall use the criteria and methodology defined in this clause and no other evaluation criteria or methodologies shall be permitted.

33.2 To evaluate a bid, the Employer shall consider the following:

- (a) the bid price, excluding Provisional Sums and the provision, if any, for contingencies in the Summary Bill

of Quantities for admeasurement contracts or Schedule of Prices for lump sum contracts, but including Daywork items, where priced competitively; and

- (b) price adjustment for correction of arithmetic errors, discounts, non-conformities, due to the supplementary criteria as defined in Section IV, and Margin of Preference, if applicable.

33.3 If this Bidding Document allows Bidders to quote separate prices for different contracts, and to award multiple contracts to a single Bidder, the methodology to determine the lowest evaluated price of the contract combinations, including any discount offered in the Bid Submission Form, is specified in Section IV (Evaluation and Qualification Criteria).

33.4 If the bid for an admeasurement contract, which results in the lowest Evaluated Bid Price, is seriously unbalanced, front loaded or substantially below updated estimates or if any item in the Priced Activity Schedule is front loaded or contains an erroneous amount in the opinion of the Employer, the Employer may after clarification require the Bidder to produce detailed price analysis for any or all items that the amount of the performance security be increased at the expense of the Bidder.

34. Comparison of Bids

34.1 The Employer shall compare all substantially responsive bids in accordance with ITB 33 to determine the lowest evaluated bid.

35. Qualification of the Bidder

35.1 The Employer shall determine to its satisfaction whether the Bidder that is selected as having submitted the lowest evaluated substantially responsive bid meets the qualifying criteria.

36. Employer's Right to Accept Any Bid, and to Reject Any or All Bids

36.1 The Employer reserves the right to accept or reject any bid, and to annul the bidding process and reject all bids at any time prior to contract award, without thereby incurring any liability to Bidders.

F. Award of Contract

37. Award Criteria

37.1 Subject to ITB 36.1, the Employer shall award the Contract to the Bidder whose offer has been determined to be the lowest evaluated bid and is substantially responsive to the Bidding Document, provided further that the Bidder is determined to be qualified to perform the Contract satisfactorily.

38. Notification of Award

38.1 Prior to the expiration of the period of bid validity, the Employer shall, for contract amount above the prescribed

threshold, notify the selected bidder of the proposed award and accordingly notify unsuccessful bidders. Subject to Challenge and Appeal the Employer shall notify the selected Bidder, in writing, by a Letter of Acceptance for award of contract. The Letter of Acceptance shall specify the sum that the Employer will pay the Contractor in consideration of the execution and completion of the Works (hereinafter and in the Conditions of Contract and Contract Forms called “the Contract Price”) and the requirement for the Contractor to remedy any defects therein as prescribed by the Contract. Within seven days from the issue of Letter of Acceptance, the Employer shall publish on the Public Procurement Portal (publicprocurement.govmu.org) and the Employer’s website, the results of the Bidding Process identifying the bid and lot numbers and the following information:

(i) name of the successful Bidder, and the Price it offered, as well as the duration and summary scope of the contract awarded; and

(ii) an executive summary of the Bid Evaluation Report.

38.2 Until a formal contract is prepared and executed, the notification of award shall constitute a binding Contract.

39. Signing of Contract

39.1 Promptly upon issue of Letter of Acceptance, the Employer shall send to the successful Bidder the Contract Agreement.

39.2 Within twenty-one (21) days of receipt of the Contract Agreement, the successful Bidder shall sign, date, and return it to the Employer.

40. Performance Security

40.1 Within twenty-one (21) days of the receipt of the Letter of Acceptance from the Employer, the successful Bidder shall furnish the Performance Security in accordance with the conditions of contract, using for that purpose the Performance Security Form included in Section VIII (Contract Forms).

40.2 Failure of the successful Bidder to submit the above-mentioned Performance Security or to sign the Contract Agreement within the prescribed delay shall constitute sufficient grounds for the annulment of the award and forfeiture of the bid security.

- Preference Security** 40.3 The successful bidder having benefitted from a Margin of Preference shall provide a Preference Security, **as specified in the BDS**. The amount for the Preference Security shall be the difference between the price quoted by the selected bidder and that of the lowest evaluated bid which would have been selected for award of contract, if the said Margin of Preference was not applicable
- 41. Advance Payment and Security** 41.1 The Public Body shall provide an Advance Payment on the Contract Price as stipulated in the GCC, subject to a maximum amount, as stated in the BDS. The Advance Payment shall be guaranteed by a security as per the format contained in Section VIII.
- 42. Plant and Materials on site** 42.1 Unless otherwise **specified in BDS** interim payment for Plant and Material on site is applicable as per GCC 39.7.
- 43. Debriefing** 43.1 The Employer shall promptly attend to all requests for debriefing for the contract, made in writing, and within 30 days from the date of the publication of the award or date the unsuccessful bidders are informed about the award, whichever is the case, by following regulation 9 of the Public Procurement Regulations 2008 as amended.

Section II- Bidding Data Sheet

A. General	
ITB 1.1	<p>The Public Body is: The District Council of Moka</p> <p>The Works are for Construction of Drain Network to Rivulet Dickson in vicinity of Boodhooa Road and School Road at Dagotiere</p> <p>The name and identification of the Contract are W/OAB/03/2016</p> <p>The Project is Construction of Drain Network to Rivulet Dickson in vicinity of Boodhooa Road and School Road at Dagotiere</p>
ITB 1.2	The Intended Completion period is 120 days from start date]
ITB 2.1	The Funding Agency is: The District Council of Moka
ITB 3.2	<p>The address to file Challenges in respect of this procurement is: The Chief Executive, The District Council of Moka, Quartier Militaire</p> <p>The address to file Application for Review is:</p> <p style="text-align: center;">The Chairman Independent Review Panel, 9th Floor, Wing B Emmanuel Anquetil Building Pope Hennessy Street Port Louis Tel : 2013921</p>
ITB 5.4	<p>The list of debarred firms according to the Debarment process may be obtained from the web site of the Procurement Policy Office: ppo.govmu.org</p>
ITB 6.2	The information required from bidders in ITB Sub-Clause 6.2 is modified as follows: <i>[list any additions or deletions to list in ITB Sub-Clause 6.2; otherwise state “none”].</i>
ITB 6.2 (c)	<i>Contractors should have at least five years of experience for works of similar nature.</i>
ITB 6.2 (g)	The assessment of the financial soundness of the company shall be on a pass/fail basis on its overall performance including its profitability.
ITB 6.4 (a)	<p>The Contractor must either:</p> <p style="padding-left: 40px;">(a) have a minimum average annual financial amount of construction of Rs 10.0M over the last 3 years.</p> <p style="text-align: center;">or</p>

	(b) have a valid registration grade of E with the CIDB.
ITB 6.4 (b)	(A1)The Contractor shall demonstrate that it is registered with the CIDB with specialization in the following area(s) : Building Construction works
ITB 6.4 (c)	The essential equipment to be made available for the Contract by the successful Bidder shall be: backhoe loader, breaker, skid steer loader, concrete mixer, miscellaneous (pumps, vibrator, etc)
ITB 6.4 (d)	A contract manager/supervisor with five years experience in works of an equivalent nature and volume including no less than three years as Manager
ITB 6.4 (e)	The minimum amount of liquid assets and/or credit facilities net of other contractual commitments of the successful Bidder shall be 0.5M
B. Bidding Documents	
ITB 8.1	The Public Body’s address for clarification is: The Chief Executive, The District Council of Moka, Quartier Militaire Country: Mauritius Telephone: 435 5531 Facsimile number: 435 5685 Electronic mail address: ceomfdc@intnet.mu
C. Preparation of Bids	
ITB 13	Any additional materials required to be completed and submitted by the Bidders are none.
ITB 17.1	The Contract is not subject to price adjustment in accordance with GCC Clause 44.
ITB 17.2	Interim Payment for Plant and Material on site is not applicable.
ITB 19.1	The Bid shall be valid for 90 days after the deadline set for the submission of bid, the deadline being counted as day one of the validity period.
ITB 20.1	<ul style="list-style-type: none"> • Bid shall include a subscription to a Bid Securing Declaration or <i>[If a Bid Security is required insert: “Bid security shall be valid up to 30 days beyond the validity period set for the bid. The closing date for submission of bids shall be considered as day one”.</i> <p><i>Note: The Bid Security may be calculated as a fixed amount rounded to the nearest thousand rupees based on around 1 % of the estimated value of the works].</i></p>

D. Submission of Bids	
ITB 23.1	The deadline for submission of bids shall be 20 June 2016, Noon at latest
	<p>The Employer's address for the purpose of Bid submission is</p> <p>Attention: The Chief Executive</p> <p>Address: The District Council of Moka, Quartier Militaire</p> <p>Floor-Room number: Ground Floor</p> <p>Country: Mauritius</p>
E. Evaluation and Comparison of Bids	
ITB 26.1	<p>The bid opening shall take place at:</p> <p>Street Address: The District Council of Moka, Quartier Militaire</p> <p>Floor/ Room number: Council Room</p> <p>Country: Mauritius</p> <p>Date: 20 June 2016</p> <p>Time: 13.00 hours at latest</p>
ITB 32	<p>32.1 A Margin of Preference shall apply as defined hereunder and in Section IV-Evaluation Criteria.</p> <p>The following procedure shall be used to apply the Margin of Preference:</p> <p>(a) responsive bids shall be classified into the following groups:</p> <ul style="list-style-type: none"> • Group A: bids offered by bidders meeting the conditions satisfying eligibility for a Margin of Preference , and • Group B: all other bids; <p>(b) for the purpose of further evaluation and comparison of bids only, all bids classified in Group B shall be increased by the percentage(s) of preference allocated to those in group A.</p> <p>32.2 Bidders applying for the Margin of Preference shall submit, as part of their bidding documents evidence of:</p> <p>(a) their incorporation in the Republic of Mauritius;</p> <p>(b) their Joint Venture Agreement or intention to legally enter into a Joint Venture Agreement to be incorporated in the Republic of Mauritius, where applicable;</p> <p>(c) the percentage of the total man-days to be deployed by local manpower with break-down indicating type of works to be entrusted to the local manpower.</p>

	(d) A financial statement signed by a certified Accountant vouching that the annual turn-over of the local Small and Medium enterprise (where applicable) does not exceed Rs 50M.
F. Award of Contract	
ITB 40.1	<p>The Standard Form of Performance Security acceptable to the Public Body shall be “a Bank Guarantee”. The Bank guarantee shall be 10% of the contract price inclusive of provisional and contingencies sum and VAT.</p> <p><i>[A Bank Guarantee shall be unconditional (on demand) (see Section VIII: Contract Forms). An amount of 5 to 10 percent of the Contract Price is commonly specified for Performance Bank Guarantees.]</i></p>
ITB 40.3	<p>For contracts up to 100M, the public body shall either retain money from progressive payments to constitute the preference security or request a security in the form of a bank guarantee at the selected bidder’s option.</p> <p>For contract above Rs 100M, the preference security in the form of a bank guarantee issued from a local commercial bank shall be submitted at the time of contract award failing which the award of contract may be annulled.</p>
ITB 42.1	<p>Interim Payment for Plant and Material on site is not applicable.</p> <p><i>[If payment for plant and material on site is applicable the Public Body may insert the list of items for which payment is applicable, as appropriate.]</i></p>

Section III - Bidding Forms

Table of Forms

Bid Submission Form.....	25
Qualification Information.....	29
Bill of Quantities	33
Form of Bid Security (Bank Guarantee).....	35

Bid Submission Form

The Bidder must prepare the Bid Submission Form on stationery with its letterhead clearly showing the Bidder's complete name and address.

Note: All italicized text is for use in preparing these form and shall be deleted from the final document.

Date: _____
 Bidder's Reference No.: _____
 Procurement Reference No: **W/OAB/03/2016**

To:

We, the undersigned, declare that:

- (a) We have examined and have no reservations to the Bidding Documents, including Addenda issued in accordance with Instructions to Bidders (ITB) Clause 10;
- (b) We offer to execute in conformity with the Bidding Documents the following Works:
 _____;
- (c) The total price of our Bid after discounts, if any, offered in item (d) below is:
 _____;
- (d) The discounts offered and the methodology for their application are:
 _____;
- (e) Our bid shall be valid for a period of _____ [*insert validity period as specified in ITB 19.1.*] days from the date fixed for the bid submission deadline in accordance with the Bidding Documents, and it shall remain binding upon us and may be accepted at any time before the expiration of that period;
- (f) We hereby confirm that we have read and understood the content of the Bid Securing Declaration attached hereto and subscribe fully to the terms and conditions contained therein, if required. We understand that non-compliance to the conditions mentioned may lead to disqualification.
- (g) If our bid is accepted, we commit to obtain a Performance Security and a Preference Security (if applicable) in accordance with the Bidding Document;
- (h) We, including any subcontractors or suppliers for any part of the contract, do not have any conflict of interest in accordance with ITB 5.4;

- (i) We are not participating, as a Bidder in more than one bid in this bidding process other than alternative offers submitted in accordance with ITB 15;
- (j) Our firm, its affiliates or subsidiaries, including any Subcontractors or Suppliers for any part of the contract, has not been declared ineligible under the laws of Mauritius;
- (k) We are not a government owned entity / We are a government owned entity but meet the requirements of ITB 5.4;⁶
- (l) We hereby “*apply/do not apply*” for Margin of Preference as provided in the bidding document;⁷
- (m) We have taken steps to ensure that no person acting for us or on our behalf will engage in any type of fraud and corruption as per the principles described hereunder, during the bidding process and contract execution:
- i. We shall not, directly or through any other person or firm, offer, promise or give to any of the Public Body’s employees involved in the bidding process or the execution of the contract or to any third person any material or immaterial benefit which he/she is not legally entitled to, in order to obtain in exchange any advantage of any kind whatsoever during the tender process or during the execution of the contract.
 - ii. We shall not enter with other Bidders into any undisclosed agreement or understanding, whether formal or informal. This applies in particular to prices, specifications, certifications, subsidiary contracts, submission or non-submission of bids or any other actions to restrict competitiveness or to introduce cartelisation in the bidding process.
 - iii. We shall not use falsified documents, erroneous data or deliberately not disclose requested facts to obtain a benefit in a procurement proceeding.

We understand that transgression of the above is a serious offence and appropriate actions will be taken against such bidders.

- (n) We understand that this bid, together with your written acceptance, shall constitute a binding contract between us, until a formal contract is prepared and executed;
- (o) We understand that you are not bound to accept the lowest evaluated bid or any other bid that you may receive; and
- (p) If awarded the contract, the person named below shall act as Contractor’s Representative:

Name:

In the capacity of:

⁶ Use one of the two options as appropriate.

⁷ Strike out as appropriate

Signed: _____

Duly authorized to
sign the Bid for and
on behalf of: _____

Date: _____

Seal of Company _____

Appendix to Bid Submission Form

Bid Securing Declaration

By subscribing to the undertaking in respect of paragraph (f) of the Bid Submission form:

I/We* accept that I/we* may be disqualified from bidding for any contract with any Public Body for the period of time that may be determined by the Procurement Policy Office under section 35 of the Public Procurement Act, if I am/we are* in breach of any obligation under the bid conditions, because I/we*:

- (a) have modified or withdrawn my/our* Bid after the deadline for submission of bids during the period of bid validity specified by the Bidder in the Letter of Bid; or
- (b) have refused to accept a correction of an error appearing on the face of the Bid; or
- (c) having been notified of the acceptance of our Bid by the (*insert name of public body*) during the period of bid validity, (i) have failed or refused to execute the Contract, if required, or (ii) have failed or refused to furnish the Performance Security, in accordance with the Instructions to Bidders.

I/We* understand this Bid Securing Declaration shall cease to be valid (a) in case I/we am/are the successful bidder, upon our receipt of copies of the contract signed by you and the Performance Security issued to you by me/us ; or (b) if I am/we are* not the successful Bidder, upon the earlier of (i) the receipt of your notification of the name of the successful Bidder; or (ii) thirty days after the expiration of the validity of my/our* Bid.

In case of a Joint Venture, all the partners of the Joint Venture shall be jointly and severally liable.

Qualification Information

*[The information to be filled in by **bidders** in the following pages shall be used for purposes of post-qualification or for verification of prequalification as provided for in ITB Clause 6. This information shall not be incorporated in the Contract. Attach additional pages as necessary. Pertinent sections of attached documents should be translated into English. If used for prequalification verification, the Bidder should fill in updated information only.]*

- 1. Individual Bidders or Individual Members of Joint Ventures**
- 1.1 Constitution or legal status of Bidder: *[attach copy]*
- Place of registration: *[insert]*
- Principal place of business: *[insert]*
- Evidence of signatory authorized to sign the bid (if applicable): *[attach]*
- 1.2 Annual amounts of construction works performed during the last *[insert number]* years *[insert amounts in the national currency equivalent in the format given hereunder].*⁸

	Project name	Client	Client's contact person	Contract Price MUR	Ongoing/ Completed	Payment received (MUR)		
						(yr)	(yr)	(yr)
(a)								
(b)								

[The selected bidder may be required, at post qualification assessment to submit, within seven days, written evidence for each of the listed projects certified by his client or by a professional (Engineer, Architect or Quantity Surveyor) having worked on those projects stating inter alia that the project was executed by the said contractor in its capacity as prime contractor. Bidders should therefore be prepared to submit these documents, if so required].

- 1.3 Number *[insert number]* of works of a nature and amount similar to the Works performed as prime Contractor over the last

⁸ This clause is not applicable for bidders having a Provisional Registration or bidders currently operating in Mauritius who are duly registered with the CIDB under the grade that covers adequately the size and type of works related to the project.

[insert number] years. [Also list details of work under way or committed, including expected completion date(s).]⁹

Project/Contract name and country	Name of client and contact person	Type of work performed and year of completion	Value of contract (national currency)
(a)			
(b)			

1.4 Major items of Contractor's Equipment proposed for carrying out the Works. *[List all information requested below. Refer also to ITB Sub-Clause 6.4 (c).]*

Item of equipment	Description, make, and age (years)	Condition (new, good, poor) and number available	Owned, leased (from whom?), or to be purchased (from whom?)
(a)			
(b)			

1.5 Qualifications and experience of key personnel proposed for administration and execution of the Contract. *[Attach biographical data. Refer also to ITB Sub-Clause 6.4 (d).]*

Position	Name	Years of experience (general)	Years of experience in proposed position
(a)			
(b)			

1.6 Proposed subcontracts and firms involved. Refer to General Conditions of Contract Clause 7.

Sections of the Works	Value of subcontract	Subcontractor (name and address)	Experience in similar work
(a)			
(b)			

[Bidders have to ascertain that sub-contractors executing works of amount Rs 500 000 are duly registered with the CIDB where applicable in accordance with CIDB (Registration of Consultant) Regulation 2014.].

1.7 Financial reports for the last *[insert number; usually 3] years: Financial Statements, Audited Accounts, etc. [List below and attach copies.]¹⁰*

⁹ This clause is not applicable for bidders having a Provisional Registration or bidders currently operating in Mauritius who are duly registered with the CIDB under the field of specialisation that covers adequately the specialisation and complexity of works related to the project.

¹⁰ This clause is not applicable for bidders having a Provisional Registration or bidders currently operating in Mauritius who are duly registered with the CIDB under the grade that covers adequately the size and type of works related to the project.

1.8 Evidence of access to financial resources to meet the qualification requirements: cash in hand, lines of credit, etc. List below and attach copies of support documents.

1.9 Name, address, and telephone, telex, and facsimile numbers of banks that may provide references if contacted by the Public Body.

1.10 Information on current litigation(s) in which the Bidder is involved.

Other party(ies)	Cause of dispute	Amount involved
(a)		
(b)		

1.11 Statement of compliance with the requirements of ITB Sub-Clause 5.4 (e).

1.12 Proposed program (service work and schedule). Description, drawings and charts, as necessary, to comply with the requirement of the bidding documents.

2. Joint Ventures 2.1 The information listed in 1.1 - 1.10 above shall be provided for each partner of the joint venture.

2.2 The information in 1.12 above shall be provided for the joint venture.

2.3 Attach the power of attorney or other acceptable document of the signatory (ies) of the Bid authorizing signature of the Bid on behalf of the joint venture.

2.4 Attach the Agreement among all partners of the joint venture (and which is legally binding on all partners), which shows that

(a) all partners shall be jointly and severally liable for the execution of the Contract in accordance with the Contract terms;

(b) one of the partners will be nominated as being in charge, authorized to incur liabilities, and receive instructions for and on behalf of any and all partners of the joint venture; and

(c) the execution of the entire Contract, including payment, shall be done exclusively with the partner in charge.

3. Additional Requirements

3.1 Bidders should provide any additional information requested in the Bidding Document.

Note: Clauses 1.2, 1.7 and 1.10 are not applicable for bidders having a Provisional Registration or bidders currently operating in Mauritius who are duly registered with the CIDB under the grade that covers adequately the size and type of works related to the project.

Clause 1.3 is not applicable where the field of specialization as categorized by CIDB referred to in the BDS by the public body covers adequately the specialization and complexity defined by the public body in the BDS.

Bill of Quantities¹¹

Objectives

The objectives of the Bill of Quantities are:

- (a) to provide sufficient information on the quantities of Works to be performed to enable bids to be prepared efficiently and accurately; and
- (b) when a Contract has been entered into, to provide a priced Bill of Quantities for use in the periodic valuation of Works executed.

In order to attain these objectives, Works should be itemized in the Bill of Quantities in sufficient detail to distinguish between the different classes of Works, or between Works of the same nature carried out in different locations or in other circumstances which may give rise to different considerations of cost. Consistent with these requirements, the layout and contents of the Bill of Quantities should be as simple and brief as possible.

Dayworks Schedule

A Dayworks Schedule should be included only if the probability of unforeseen work, outside the items included in the Bill of Quantities, is high. To facilitate checking by the Public Body of the realism of rates quoted by the bidders, the Dayworks Schedule should normally comprise the following:

- (a) A list of the various classes of labor, materials, and Constructional Plant for which basic day work rates or prices are to be inserted by the Bidder, together with a statement of the conditions under which the Contractor shall be paid for work executed on a day work basis.
- (b) Nominal quantities for each item of day work, to be priced by each Bidder at day work rates as Bid. The rate to be entered by the Bidder against each basic day work item should include the Contractor's profit, overheads, supervision, and other charges.

Provisional Sums

A general provision for physical contingencies (quantity overruns) may be made by including a provisional sum in the Summary Bill of Quantities. Similarly, a contingency allowance for possible price increases should be provided as a provisional sum in the Summary priced Bill of Quantities. The inclusion of such provisional sums often facilitates budgetary approval by avoiding the need to request periodic supplementary approvals as the future need arises. Where such provisional sums or contingency allowances are used, the Particular Conditions of Contract should state the manner in which they shall be used, and under whose authority (usually the Employer's Representative).

The estimated cost of specialized work to be carried out, or of special goods to be supplied, by other contractors (refer to GCC Clause 8) should be indicated in the relevant part of the Bill of Quantities as a particular provisional sum with an appropriate brief

¹¹ *In lump sum contracts, the "Bill of Quantities" is prepared for information; it is not contractual. The contractual document prepared by the Bidder shall be a "Schedule of Activities."*

description. A separate procurement procedure is normally carried out by the Public Body to select such specialized contractors. To provide an element of competition among the bidders in respect of any facilities, amenities, attendance, etc., to be provided by the successful Bidder as prime Contractor for the use and convenience of the specialist contractors, each related provisional sum should be followed by an item in the Bill of Quantities inviting the Bidder to quote a sum for such amenities, facilities, attendance, etc.

These Notes for Preparing a Bill of Quantities are intended only as information for the Public Body or the person drafting the Bidding Documents. They should not be included in the final Documents.

Form of Bid Security (Bank Guarantee)

.....*Bank's Name and Address of issuing Branch or Office*.....

Beneficiary: *Name and Address of Public Body*.....

Date:

BID GUARANTEE No.:

We have been informed that*name of the Bidder*..... (hereinafter called "the Bidder") has submitted to you its bid dated..... (hereinafter called "the Bid") for the execution of*name of contract* under Invitation for Bids No.....*IFB number* ("the IFB").

Furthermore, we understand that, according to your conditions, bids must be supported by a bid security.

At the request of the Bidder, we*name of Bank* hereby irrevocably undertake to pay you any sum or sums not exceeding in total an amount of*amount in figures*..... (*amount in words*.....) upon receipt by us of your first demand in writing accompanied by a written statement stating that the Bidder is in breach of its obligation(s) under the bid conditions, because the Bidder:

- (a) has modified or withdrawn its Bid after the deadline for submission of its bid during the period of bid validity specified by the Bidder in the Form of Bid; or
- (b) has refused to accept a correction of an error appearing on the face of the Bid; or
- (c) having been notified of the acceptance of its Bid by the Public Body during the period of bid validity, (i) has failed or refused to sign the contract Form, if required, or (ii) has failed or refused to furnish the performance security, in accordance with the Instructions to Bidders.

This guarantee shall expire: (a) if the Bidder is the successful bidder, upon our receipt of copies of the contract signed by the Bidder and the performance security issued to you upon the instruction of the Bidder; or (b) if the Bidder is not the successful bidder, upon the earlier of (i) our receipt of a copy of your notification to the Bidder of the name of the successful bidder; or (ii) thirty days after the expiration of the Bidder's Bid.

Consequently, any demand for payment under this guarantee must be received by us at the office on or before*Public Body to insert date*.....

.....*Bank's seal and authorized signature(s)*.....

Section IV - Evaluation Criteria

This section contains supplementary criteria that the Employer shall use to evaluate bids.

1. Evaluation

In addition to the criteria listed in ITB 33 the following criteria shall apply:

(a) Adequacy of Technical Proposal

Evaluation of the Bidder's Technical Proposal will include an assessment of the Bidder's technical capacity to mobilize key equipment and personnel for the contract consistent with its proposal regarding work methods, scheduling, and material sourcing in sufficient detail and fully in accordance with the requirements stipulated in Section V (Employer's Requirements).

(b) Multiple Contracts

Pursuant sub-clause 1.1 of the Instructions to Bidders, if Works are grouped in multiple contracts, evaluation will be as follows:

(c) Completion Time

An alternative Completion Time, if permitted under ITB 15.1, will be evaluated as follows:

(d) Technical Alternatives

Technical alternatives, if permitted under ITB 15.1, will be evaluated as follows:

(e) Margin of Preference

A Margin of Preference for employment of local manpower shall be applicable as follows:

1.1 For International Bidding

A bidder, incorporated in the Republic of Mauritius and employing local manpower for 80 % or more of the total man-days deployed for the execution of a Works contract, shall be eligible for a preference of 15 %.

1.2 For National Bidding

- (i) A local Small and Medium Enterprise, having an annual turnover not exceeding Rs 50 million or a joint venture consisting of local Small and Medium Enterprises having an aggregate annual turnover not exceeding Rs50

million and employing local manpower for 80 % or more of the total man-days deployed for the execution of a Works contract, shall be eligible for a Margin of Preference of 20 %.

- (ii) Any bidder incorporated in the Republic of Mauritius not satisfying all the conditions mentioned in (a) above but employing local manpower for 80 % or more of the total man-days deployed for the execution of a Works contract, shall be eligible for a Margin of Preference of 10 %.

Note: Local manpower shall mean employees on the payroll of the Contractor as well as those for subcontractors executing works on the site.

PART 2 – Employer’s Requirements

Section V - Employer's Requirements

Table of Contents

Specifications	40
Drawings.....	42
Supplementary Information	43

Specifications

A set of precise and clear Specifications is a prerequisite for bidders to respond realistically and competitively to the requirements of the Employer without qualifying or conditioning their bids. In the context of international competitive bidding, the Specifications must be drafted to permit the widest possible competition and, at the same time, present a clear statement of the required standards of workmanship, materials, and performance of the goods and services to be procured. Only if this is done shall the objectives of economy, efficiency, and fairness in procurement be realized, responsiveness of bids be ensured, and the subsequent task of Bid evaluation facilitated. The Specifications should require that all goods and materials to be incorporated in the Works be new, unused, of the most recent or current models, and incorporate all recent improvements in design and materials unless provided otherwise in the Contract.

Samples of Specifications from previous similar projects in the same country are useful to prepare Specifications. The use of metric units is encouraged by the Government of the Republic of Mauritius. Most Specifications are normally written specially by the Employer or Employer's Representative to suit the Contract Works in hand. There is no standard set of Specifications for universal application in all sectors in all countries, but there are established principles and practices, which are reflected in these documents.

There are considerable advantages in standardizing General Specifications for repetitive Works in recognized public sectors, such as highways, ports, railways, urban housing, irrigation, and water supply, in the same country or region where similar conditions prevail. The General Specifications should cover all classes of workmanship, materials, and equipment commonly involved in construction, although not necessarily to be used in a particular Works Contract. Deletions or addendums should then adapt the General Specifications to apply them to the particular Works.

Care must be taken in drafting Specifications to ensure that they are not restrictive. In the Specifications of standards for goods, materials, and workmanship, recognized international standards should be used as much as possible. Where other particular standards are used, whether national standards of Mauritius or other standards, the Specifications should state that goods, materials, and workmanship that meet other authoritative standards, and which ensure substantially equal or higher quality than the standards mentioned, shall also be acceptable. To that effect, the following sample clause may be inserted in the Special Conditions or Specifications.

“Equivalency of Standards and Codes

Wherever reference is made in the Contract to specific standards and codes to be met by the goods and materials to be furnished, and work performed or tested, the provisions of the latest current edition or revision of the relevant standards and codes in effect shall apply, unless otherwise expressly stated in the Contract. Where such standards and codes are national, or relate to a particular country or region, other authoritative standards that ensure a substantially equal or higher quality than the standards and codes specified shall be accepted subject to the Employer's Representative's prior review and written consent. Differences between the standards specified and the proposed alternative standards shall be fully described in writing by the Contractor and submitted to the Employer's Representative at least 28 days prior to the date when the Contractor desires the Employer's Representative's consent. In the event the Employer's Representative determines that

such proposed deviations do not ensure substantially equal or higher quality, the Contractor shall comply with the standards specified in the documents.”

“Technical Alternative and Completion Time”

The Employer shall indicate in this section if technical or completion date alternative is allowed and where technical alternative is allowed the Employer shall also indicate the sections where such alternatives are allowed. Evaluation methodologies for such alternatives shall be contained in Section IV.

These Notes for Preparing Specifications are intended only as information for the Employer or the person drafting the bidding documents. *They should not be included in the final documents.*

THE DISTRICT COUNCIL OF MOKA

Construction of drain network to Rivulet Dickson in vicinity of Boodhooa Road and School Road at Dagotiere

Item	Description of Work	Unit	Qty	Rate (Rs.)	Amount (Rs.)
1	<p><i>Dredging and construction of masonry open drain as per location on drawing</i></p> <p>Excavation and construction of a masonry drain at the location described in the drawing all to be done as per specifications below and includes the following:</p> <ul style="list-style-type: none"> - The existing canal to be dredged mechanically so as to clear the site where necessary and excavation in all materials including rock to receive reinforced concrete base. - Fixing of formwork (cast in-situ) and reinforcement to line and level and stripping. - Casting of concrete, compaction, testing and curing. - Supply and place shaped masonry stones with cement mortar - Supply and place 75mm dia UPVC weepholes - Final cleaning of drains and carting away of debris and excess materials <p>A masonry drain to be constructed of top width 1500 mm, bottom width 1000mm and depth 1500 mm as per site condition to connect to the existing culverts found along the Upper Dagotiere Branch Road</p>	LM	955		
2	<p><i>Demolition and reconstruction of 3 nos. reinforced culverts as per location on drawing and road reprofiling</i></p> <p>The existing reinforced concrete culvert to be demolished and new reinforced concrete culverts as per specifications below and includes the following:</p> <ul style="list-style-type: none"> - Demolition of reinforced or unreinforced 	Nos	3		

Item	Description of Work	Unit	Qty	Rate (Rs.)	Amount (Rs.)
	<p>concrete or masonry structures including block walls or reinforced concrete structures</p> <ul style="list-style-type: none"> - Loading, carting away and disposal of all excess material - Excavation in all materials including rock or existing concrete or masonry drains to level inclusive of depth of cover slab and disposal of excess material - Making and erection of formwork for bridgeworks, supply, cutting and placing of concrete - Cutting and bending of reinforcement bars, fixing of prefabricated concrete elements, concrete curing and supplying and applying material for impregnation of concrete surfaces. -Supply and placing of concrete bed, mortar jointing, etc. -Striking off formwork -Supply and placing of sleeves or split ducts to cater for the relocation of existing CWA pipes (including house connections), Mauritius Telecom or other services ducts in accordance with the requirements of the relevant authorities. -Backfilling and making good/reinstatement of the sides of the constructed drains as directed by the Engineer. -Cleaning of the culvert during construction period, frequency as directed by the Engineer. -Disposal of any surplus excavated materials and carting away. - Fixing of heavy-duty handrails as per drawing on both sides of the road over length of crossing. - Spreading, compacting and smoothing of asphalt concrete including spraying tack coat of 0.6 litre/m² and supply and laying of asphaltic concrete base course 0/14 for reshaping with 4.5% total mix binder content (minimum thickness 25mm) including on narrow surfaces and other areas which should be done manually. - Allowing for and complying with connection details of raised kerbs with 				

Item	Description of Work	Unit	Qty	Rate (Rs.)	Amount (Rs.)
	<p>gullies (where applicable)</p> <ul style="list-style-type: none"> - Allowing for the manufacture, supply, transport and fixing of 2 nos. metal grating covers and frames in accordance with drawings each for 3 nos. culverts on roads - Reshaping and reinstatement of road with premix asphalt for proper drainage of road runoff water. 				
3	<p>Construction of covered reinforced concrete drain</p> <p>Reinforced Concrete Drain size 1200 wide x 1200 mm internal dimensions (Grade 25) flush to road level comprising of 50 mm blinding layer, vertical sides and reinforced pre-cast cover slab as per drawings including all necessary excavation in rock, grading bottom, formwork, finishes, removal/carting away of surplus spoil from site and road reinstatement</p> <p>Drain can be Pre-Cast type or construct – cast in situ.</p> <p>The Contractor should make provision for any temporary traffic diversion and possible relocation of services and the rate is inclusive of any associated costs related thereby. The Contractor shall also liaise with private property owners and obtain written wayleave consent for construction of drain within existing canal/ditch</p>	LM	75		
	<p>The Contractor should liaise with the District Council for a site visit and take cognizance of the site condition and exact nature of work before submitting the quotation.</p> <p>The prospective tenderer should obtain all wayleaves and take appropriate traffic measures prior to start the work and during the construction period. Any services damaged during the course of the</p>				

Item	Description of Work	Unit	Qty	Rate (Rs.)	Amount (Rs.)
	work should be reinstated by the contractor.				
	SUB TOTAL				
	VAT 15%				
	CONTINGENCIES				750,000
	TOTAL AMOUNT				

VALIDITY OF OFFER : 90 days

CONTRACTUAL PERIOD : 60 days

NAME OF CONTRACTOR :

SIGNATURE :

SEAL OF COMPANY (If any) :

DATE :

Drawings

Insert here a list of Drawings. The actual Drawings, including site plans, should be attached to this section or annexed in a separate folder.

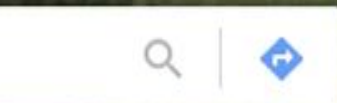

Dagotiere Village Hall

Google

Ajageer Supermarket

365 M

235 M

55 M

75 M

100 M

110 M

35 M

55 M

2 NOS. CULVERTS

Dagotiere Branch Road

Dagotiere Branch Road

Kalimaye Rd

Kalimaye Rd

Kalimaye Rd

School Rd

School Rd

Shivala Rd

Shivala Rd

Shivala Rd

B50

B116

B116

B50

B50

B116

B116

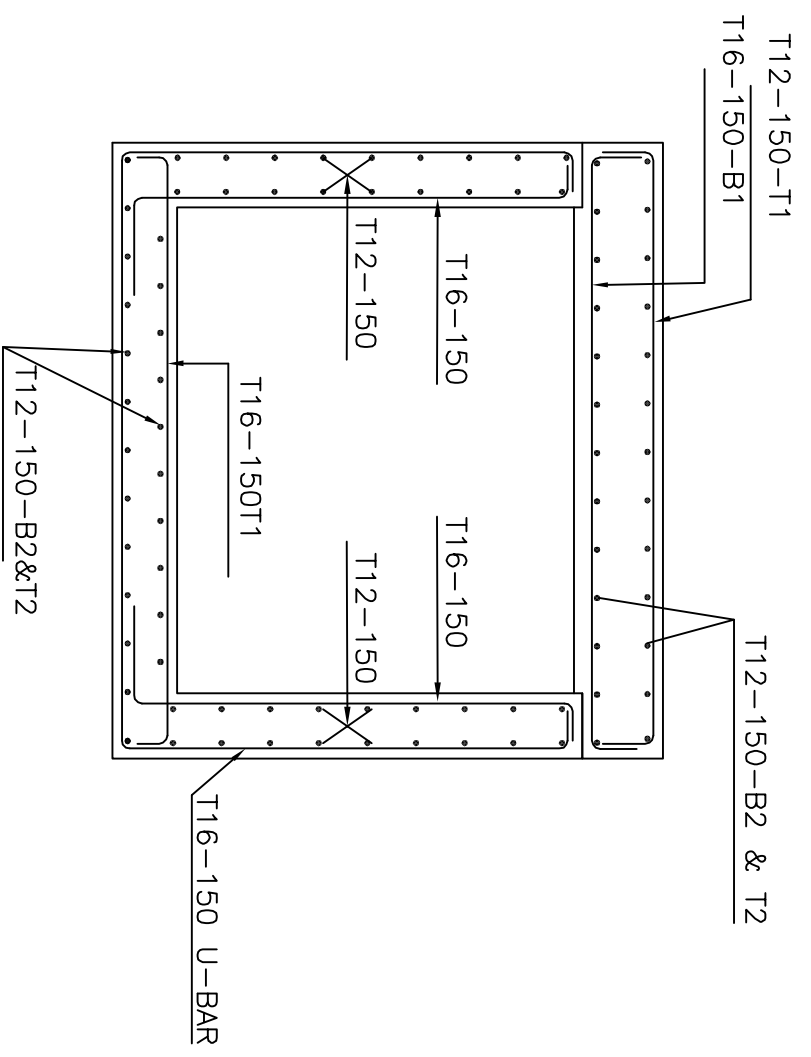
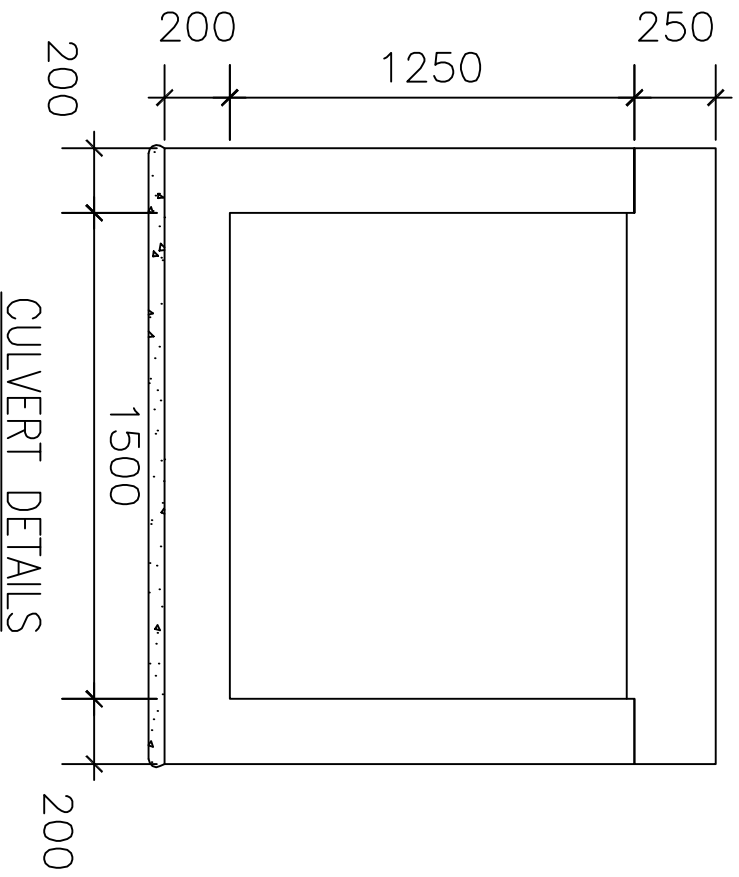

Notes:

1. Concrete to be grade 30/20.
2. Reinforcement to be high yield deformed to BS 4449.
3. Cover to reinforcement to be 30mm.
4. All dimensions are in millimetres.

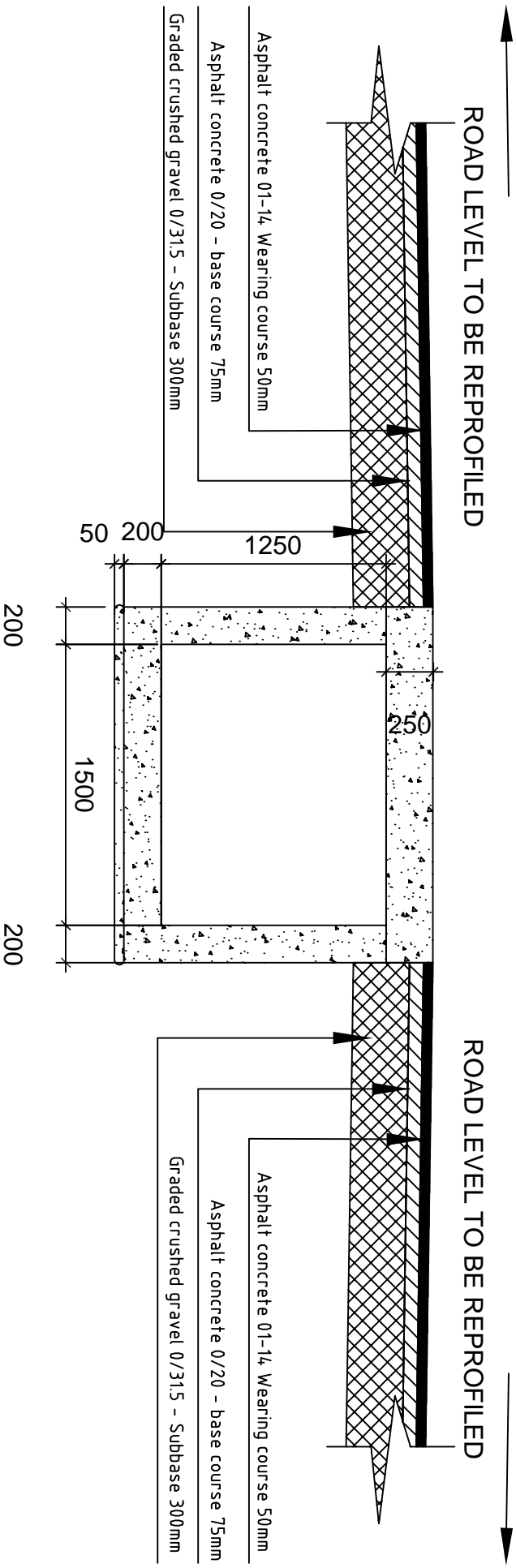

TYPICAL SECTION OF CULVERT

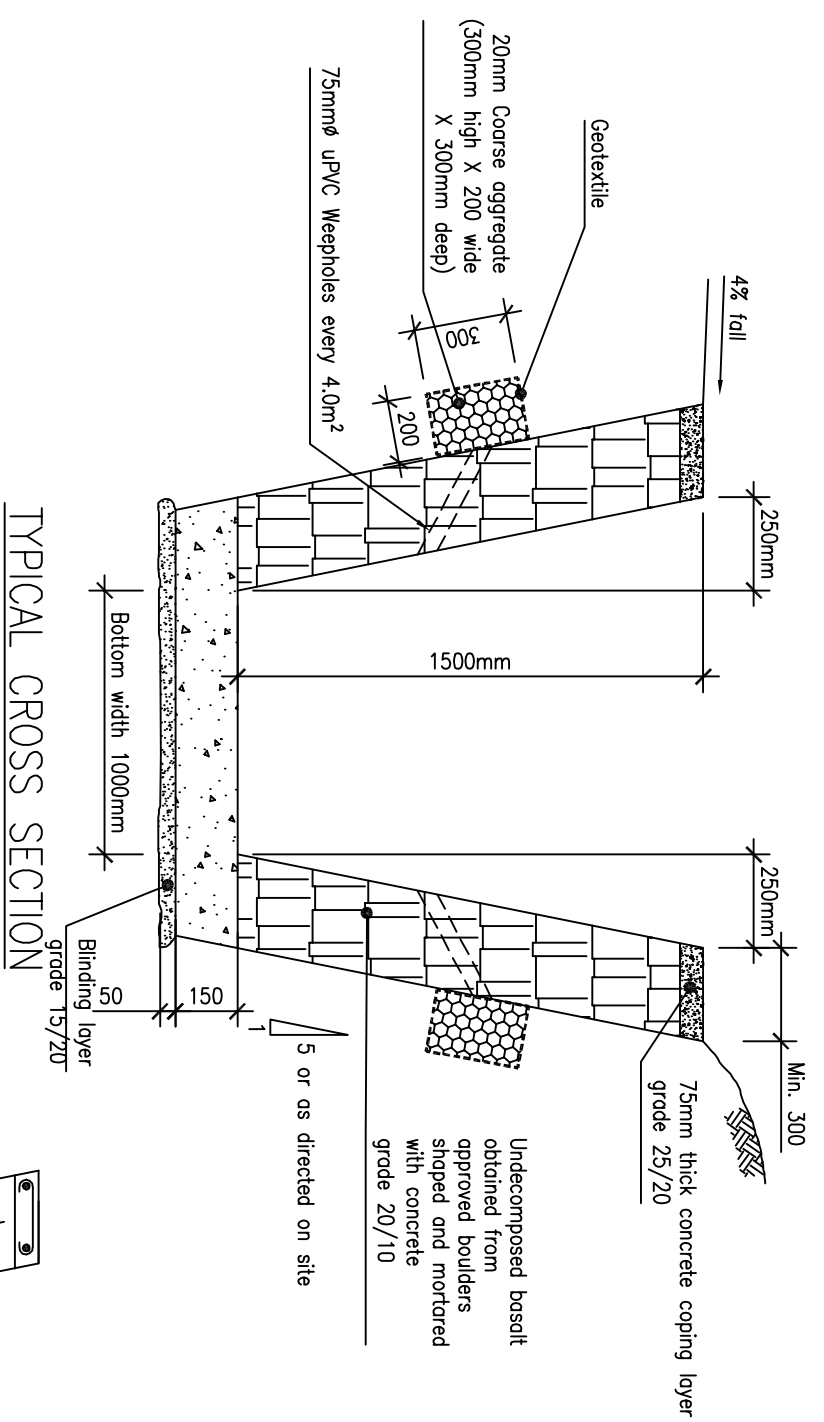

- Notes:-
1. Concrete to be of grade 25.
 2. Cover to reinforcement 40mm.
 3. All dimensions in millimetres

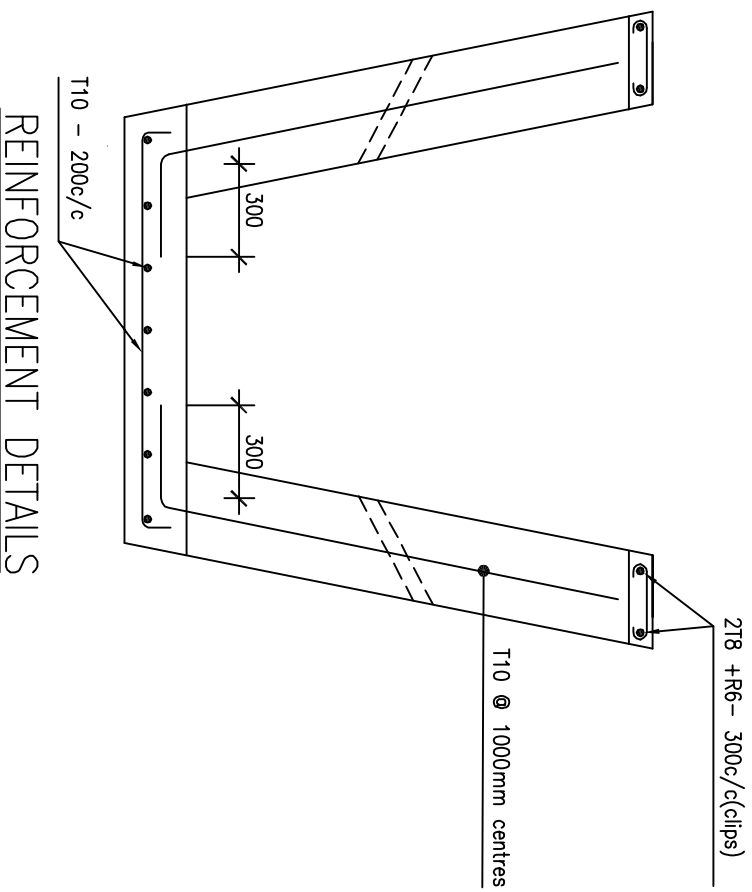

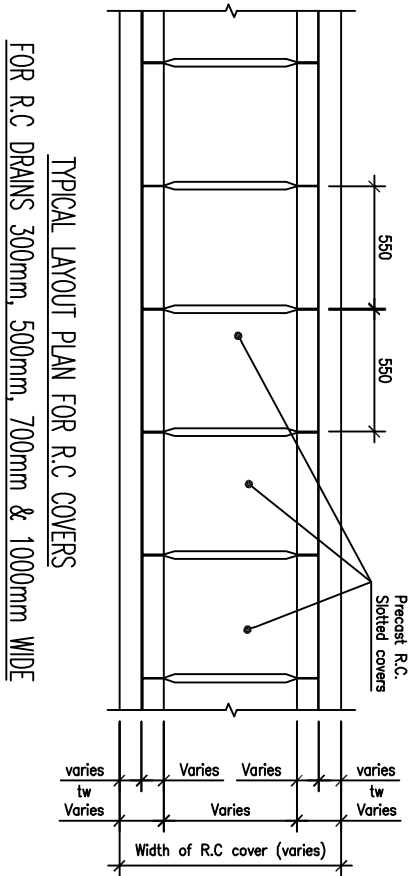
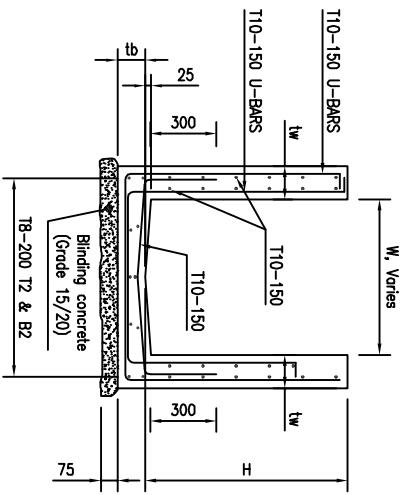
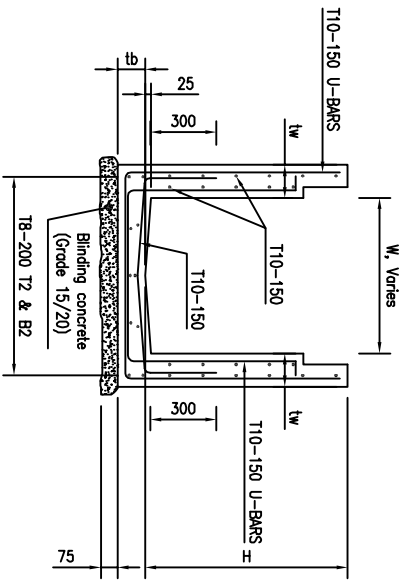

TYPICAL LAYOUT PLAN FOR R.C. COVERS
FOR R.C DRAINS 300mm, 500mm, 700mm & 1000mm WIDE

TYPICAL DETAILS OF REINFORCED CONCRETE DRAINS,
(COVERED WITH PRECAST OR IN-SITU SLABS)

TYPICAL DETAILS OF REINFORCED CONCRETE DRAINS,
(OPEN)

TABLE OF DIMENSIONS FOR R.C DRAINS

H	W	tw	tb
1200	1200	200	200

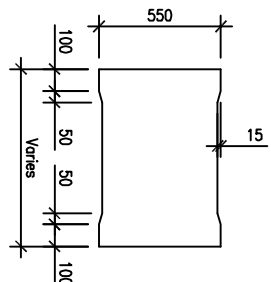
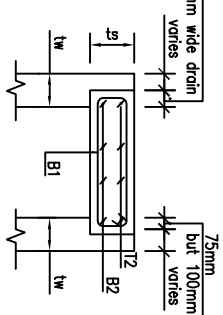
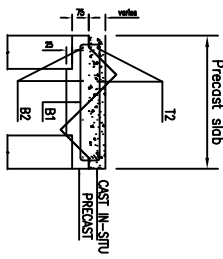

TYPICAL REINFORCEMENT DETAILS FOR R.C COVERS (TYPE B)

R.C COVER DETAILS

DETAILS OF PRECAST FORMER
AND IN-SITU SLAB (TYPE A)
(Reinforcement as table)

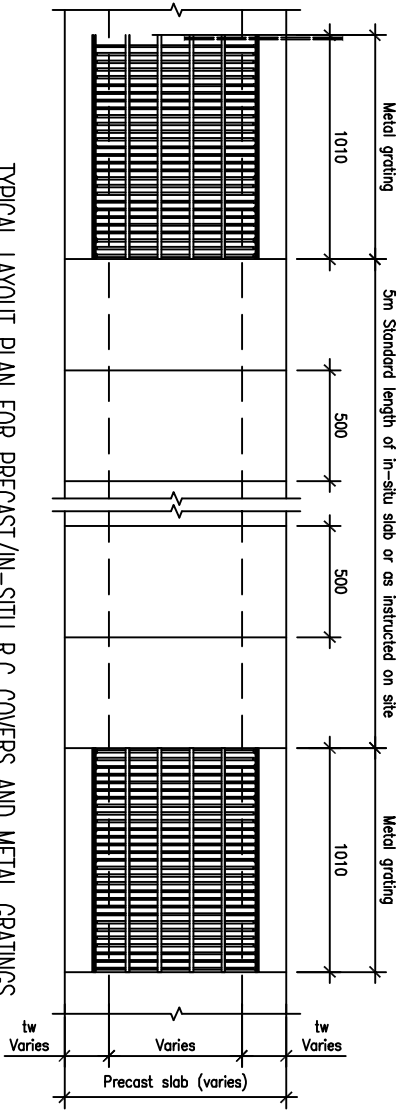

TABLE OF DIMENSIONS FOR R.C COVERS

DRAIN WIDTH	tw	PRECAST SLAB TYPE A	WIDTH OF COVER TYPE B	ts	REINFORCEMENT
300	150	600	450	200	T12 at 175c/c (B1) T8 at 150c/c (B2 & T2)
500	150	800	650	200	T12 at 150c/c (B1) T8 at 150c/c (B2 & T2)
700	175	1050	850	200	T12 at 125c/c (B1) T8 at 150c/c (B2 & T2)
1000	200	1400	Not to be used	200	T12 at 100c/c (B1) T8 at 150c/c (B2 & T2)

For drains under footpaths, all dimensions to be the same except 'ts' to be 150mm.

- Notes:
1. Concrete to be grade 30/20.
 2. Reinforcement to be high yield deformed to BS 4449.
 3. Cover to reinforcement to be 30mm.
 4. All dimensions are in millimetres.
 5. 1000mm wide drain covers to be cast by formers and in-situ slab only.
 6. Weepholes every 4.0m on both sides Height to be determined on site

TYPICAL LAYOUT PLAN FOR PRECAST/IN-SITU R.C COVERS AND METAL GRATINGS
FOR ABSORPTION DRAINS

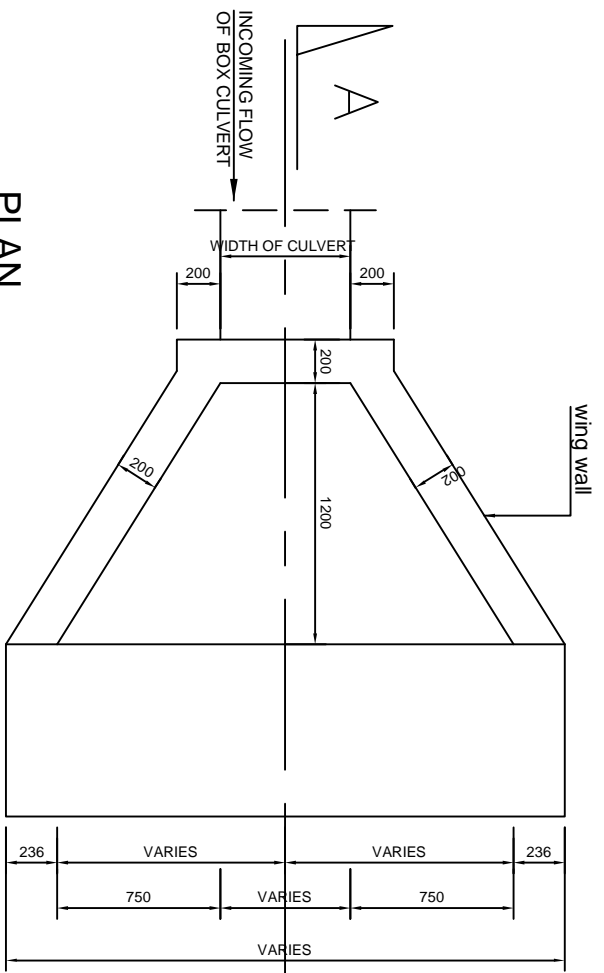

PLAN

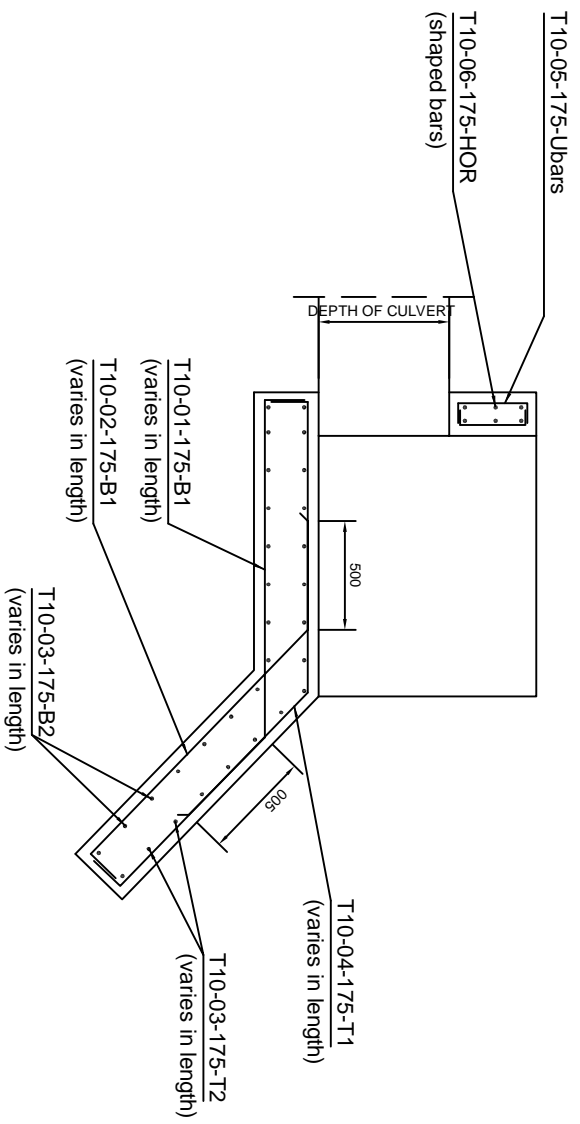

REINFORCING DETAILS

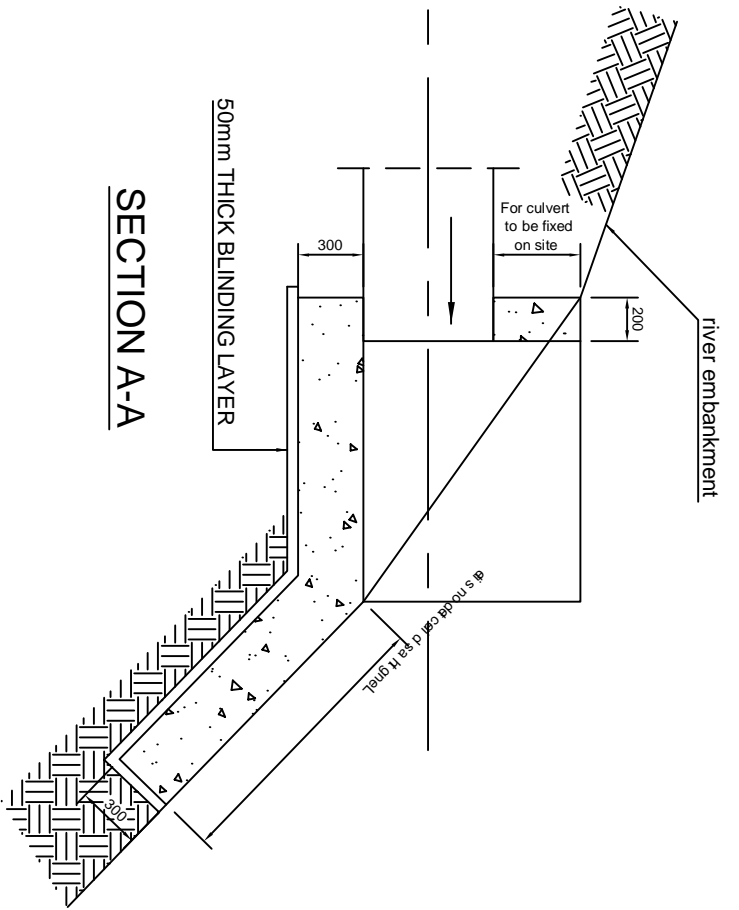

SECTION A-A

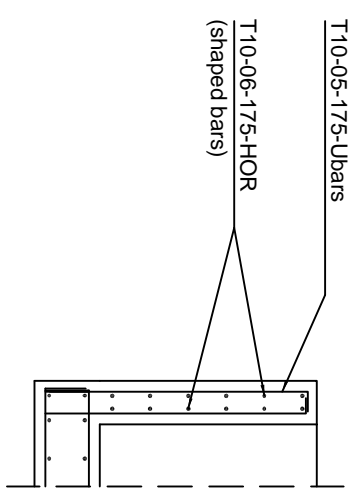

REINFORCING DETAILS FOR WING WALLS

NOTES:-

1. Concrete to be grade 30/20.
2. Reinforcement to be high yield deformed to BS 4449.
3. All dimensions are in millimetres.
4. 50mm min. cover to all reinforcement.

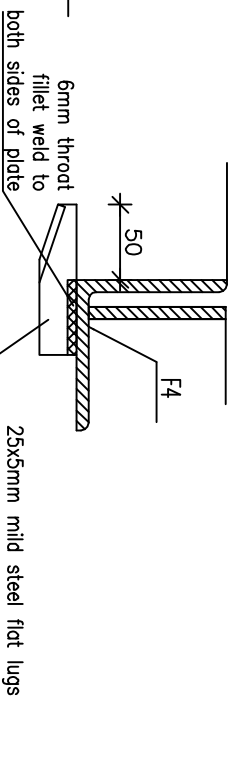
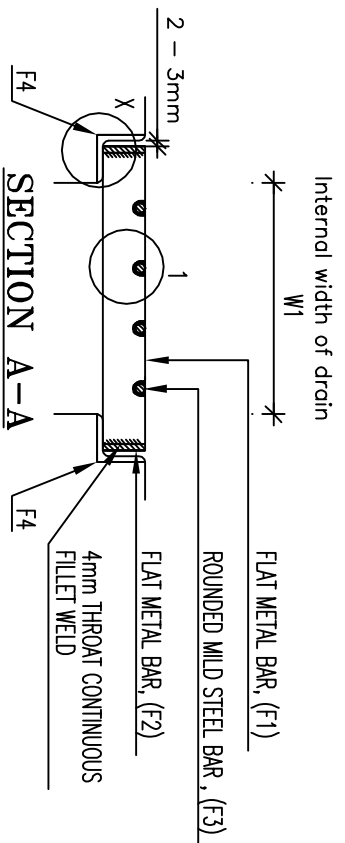

DETAIL X

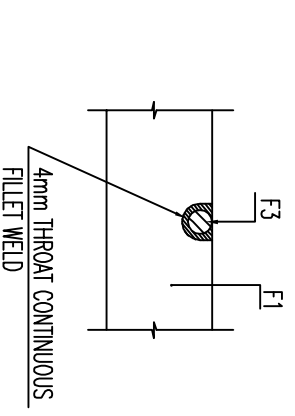
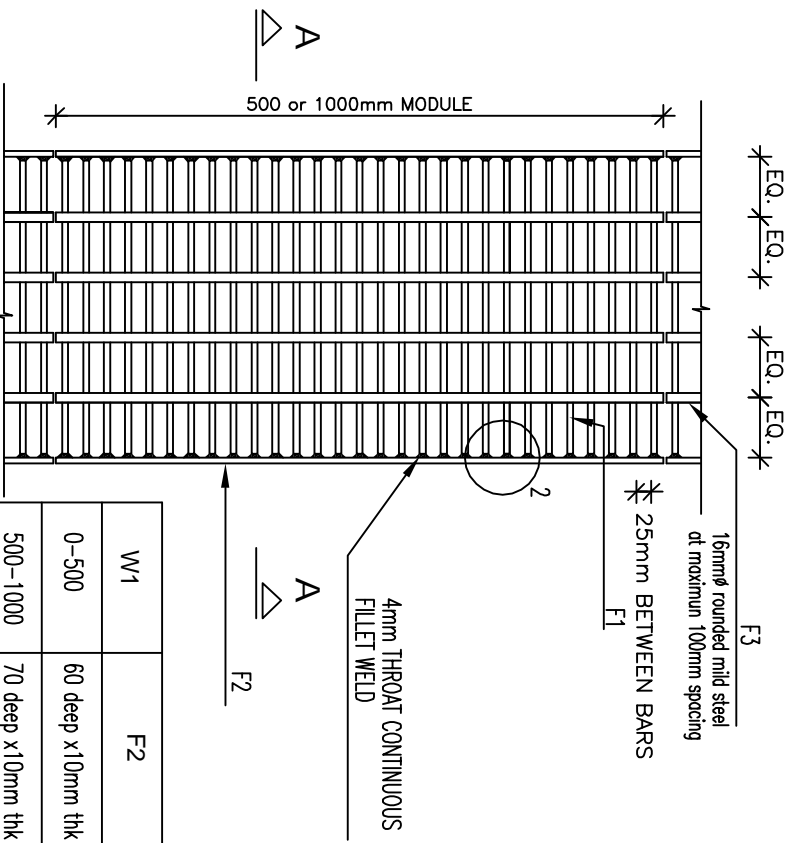

DETAIL 1

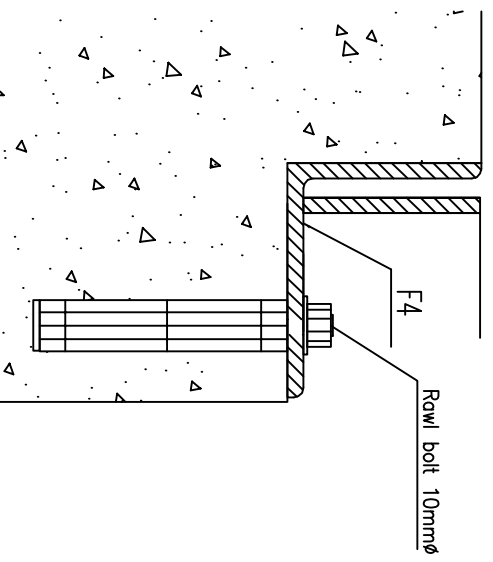

FIXING DETAILS

W1	F2	F1	F3	F4	MODULE WIDTH (mm)
0-500	60 deep x10mm thk	60 x 8mm thick	16mmØ rounded mild steel	70x70x10 (Galvanised angle iron)	1000
500-1000	70 deep x10mm thk	70 x10mm thick	16mmØ rounded mild steel	80x80x10	500
1000-1500	70 deep x10mm thk	70 x10mm thick	20mmØ high tensile steel	80x80x10	500

PLAN VIEW

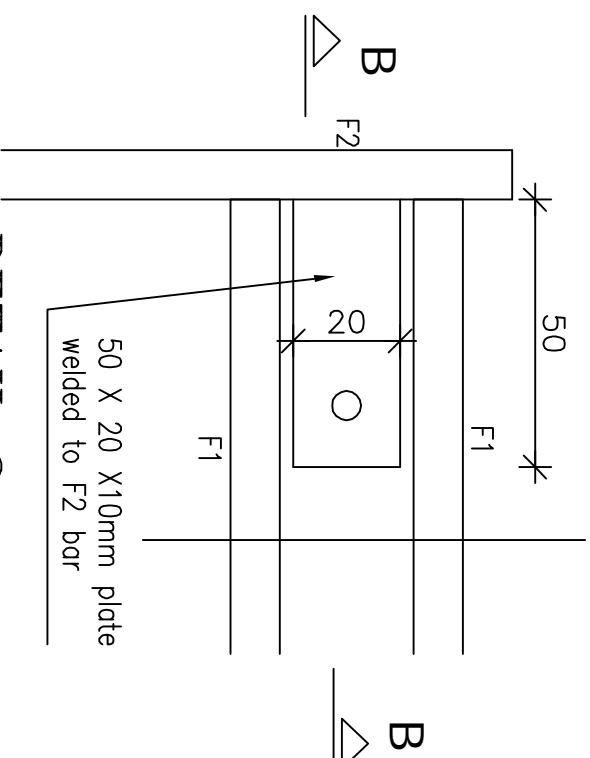
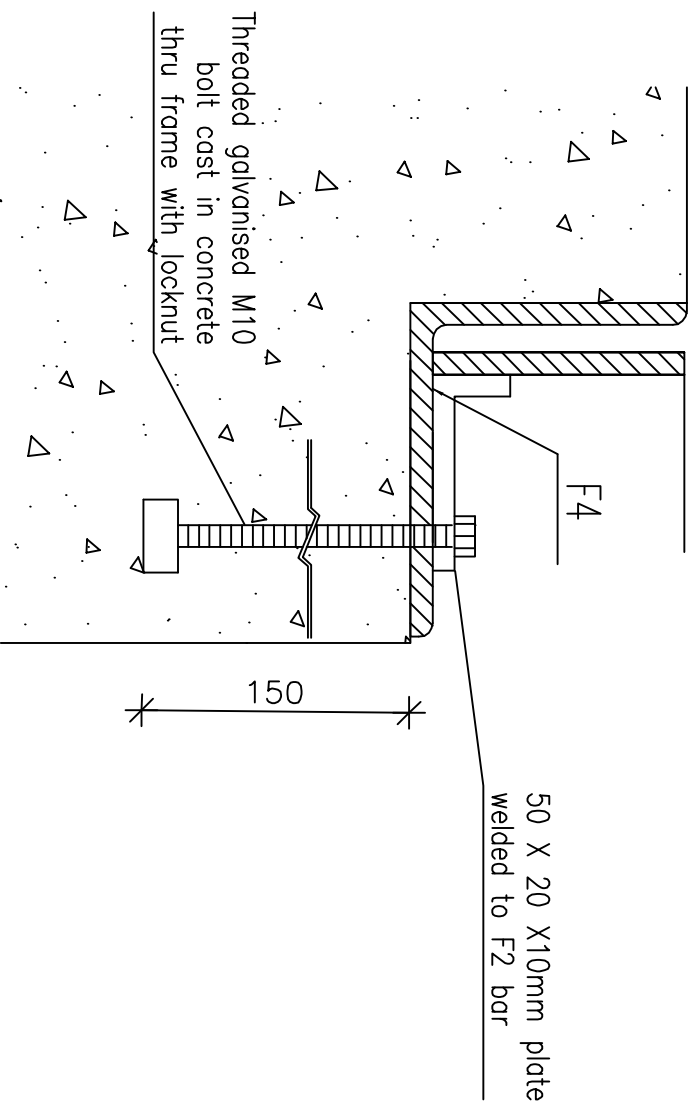

DETAIL 2

NOTES:-

1. Hot rolled sections according to BS EN 10210 Part 2.
2. Welds comply with BS EN 10111
3. All assembled metal to be hot-dipped galvanised as per BS EN 150 1461 after manufacture
4. All welding to be 4mm throat continuous fillet weld
5. Number of bars F3 as per Engineer's requirements.
6. Grating frame to be anchored by means of fishtail welded
7. If grating longitudinally located, then to be placed upside down.
8. Rawl bolts 10mm \varnothing to be fixed each side 4nos. per 500 or 1000 module.

SECTION B-B

Supplementary Information

SCHEDULE OF RATES

SCHEDULE OF RATES (Applicable for remeasurement of contract and any other miscellaneous or variation works involved)

ITEM	DESCRIPTION	UNIT	RATE	
			Rs.	Cs.
1.1	Masonry to trapezoidal open drains	M ³		
1.2	Excavation for trenches of any width in any material (including loose boulders) and the like	M ²		
1.3	Backfilling as reinstatement to culverts, drains, etc.	M ³		
1.4	Backfilling in layers not exceeding 300mm and compaction	M ³		
1.5	Formwork F1 – low structure (Height not exceeding 2m)	M ²		
1.6	Formwork F2 – Fair face finish for bridge works, decking and culverts and the like	M ²		
1.7	Concrete Class 15/20	M ³		
1.8	Concrete Class 25/20	M ³		
1.9	Concrete Class 30/20	M ³		
1.10	High tensile reinforcement	Kg		
1.11	Mild steel reinforcement	kg		
1.12	Metal grating covers to suit 1000mm wide drain	M ²		
1.13	Metal grating covers to suit 1000mm wide culvert or crossing	M ²		
1.14	Spalls 200-300mm	M ³		
1.15	Asphaltic concrete wearing course minimum 40mm thick	M ²		

1.16	Asphaltic concrete base course for reshaping exceeding 25mm thick	M ²	
1.17	Patching and local repair in asphaltic concrete	M ²	
1.18	Demolition of masonry, concrete structures, stone wall, kerbs, blockwall and the like	M ³	
1.19	Dredging of rivers, natural watercourses	M ³	
1.20	Handrailing CHS Section	M	
	TOTAL		

SIGNATURE :

DATE :

PART 3 – Conditions of Contract and Contract Forms

Section VI. General Conditions of Contract

The General Conditions of Contract (GCC) applicable for this procurement is available on the web site of the Procurement Policy Office ppo.govmu.org under Ref. No. W/GCC 10/..... dated

The GCC can be used for both admeasurement contracts and lump sum contracts.

Section VII. Particular Conditions of Contract

Except where otherwise indicated, all PCC should be filled in by the Employer prior to issuance of the Bidding Documents. Schedules and reports to be provided by the Employer should be annexed.

These clauses should be read in conjunction with the General Conditions of Contract

A. General	
GCC 1.1 (r)	The Employer is The District Council of Moka, Quartier Militaire Attention: The Civil Engineer Mr M Ragaven
GCC 1.1 (v)	The Intended Completion Date for the whole of the Works shall be 20 November 2016
GCC 1.1 (y)	The Project Manager is: The Civil Engineer Mr M Ragaven The District Council of Moka, Quartier Militaire
GCC 1.1 (aa)	The Site is located at Construction of Drain Network to Rivulet Dickson in vicinity of Boodhooa Road and School Road at Dagotiere and is defined in drawings No. 42-1
GCC 1.1 (dd)	“The Start Date shall be 20 July 2016 ”
GCC 1.1 (hh)	The Works consist of Construction of Drain Network to Rivulet Dickson in vicinity of Boodhooa Road and School Road at Dagotiere
GCC 2.3(i)	The following documents also form part of the Contract: <ul style="list-style-type: none"> • Drawings and specification • Bill of quantity • Schedule of rates
GCC 3.1	The language of the contract is English The law that applies to the Contract is the law of Mauritius.
GCC 5.1	The Project manager <i>may</i> delegate any of his duties and responsibilities.

GCC 13.1	<p>Except for the cover mentioned in (d)(i) hereunder, the other insurance covers shall be in the joint names of the Contractor and the Employer and the minimum insurance amounts shall be:</p> <p>(a) for the Works, Plant and Materials: Rs 1.0M</p> <p>(b)for loss or damage to Equipment: Rs 1.0M</p> <p>(c)for loss or damage to property (except the Works, Plant, Materials, and Equipment) in connection with Contract: Rs 1.0M</p> <p>(d) for personal injury or death: (i) of the Contractor’s employees: Rs 1.0M (ii) of other people: Rs 1.0M</p> <p>(e) for loss or damage to materials on-site and for which payment have been included in the Interim Payment Certificate, where applicable.</p> <p>The Contractor shall choose to take the insurance covers indicated above as separate covers or a combination of the Contractor’s All Risks coupled with the Employer’s liability and First Loss Burglary, after approval of the Employer. All insurance covers shall be of nil or the minimum possible deductibles at sole expense of the contractor.</p>
GCC 14.1	Site Data are: Construction of Drain Network to Rivulet Dickson in vicinity of Boodhooa Road and School Road at Dagotiere
GCC 20.1	The Site Possession Date(s) shall be: 7 days from signature of contract
GCC 23.1 & GCC 23.2	Appointing Authority for the Adjudicator: No Adjudicator shall be appointed for this Contract.
GCC 24.	<p>In case a dispute of any kind arises between the Employer and the Contractor in connection with, or arising out of, the contract or the execution of works or after completion of works and whether before or after repudiation or other termination of Contract, including any dispute as to any opinion, instruction, determination, certificate or valuation of the Employer’s Representative, the matter in dispute shall, in the first place, be referred in writing to the employer’s representative, with a copy to the other party.</p> <p>The Employer and the Contractor shall make every effort to resolve the dispute amicably by direct informal negotiation. If, after twenty-eight (28) days, the parties have failed to resolve their dispute or difference by such mutual consultation, then either the Public Body or the Contractor may give notice to the other party of its intention to refer the matter to:</p> <p>“ the competent courts of Mauritius”</p>
GCC 24.3	Hourly rate and types of reimbursable expenses to be paid to the Adjudicator:

	Not applicable.
GCC 24.4	<p><i>For large contracts with domestic contractor or for contract with foreign contractor:</i></p> <p>Any dispute or difference in respect of which a notice of intention to commence arbitration has been given shall be finally settled by arbitration in accordance with Mauritian Laws by an Arbitrator to be appointed by both parties to the dispute or in any case of disagreement, by an Arbitrator to be appointed by a judge in Chambers of Mauritius. The Arbitrator fees will be borne by the losing party. Any decision of the Arbitrator shall be final and binding to both parties”.</p> <p><i>[In case the public body has opted not to have recourse to Arbitration as per clause GCC 24 insert “Not Applicable” in here.]</i></p>
B. Time Control	
GCC 25.1	The Contractor shall submit for approval a Program for the Works within 21 days from the date of the Letter of Acceptance.
GCC 25.3	The period between Program updates is 7 days.
C. Quality Control	
GCC 33.1	The Defects Liability Period is: 365 days.
GCC 39.7	Interim Payment for Plant and Material on site is not applicable.
D. Cost Control	
GCC 41.1 (l)	Rainfall intensity greater than 50mm as adverse weather conditions
GCC 43.1	The currency of the Employer’s country is: Mauritian Rupees.
GCC 44.1	<p>The Contract is not subject to price adjustment in accordance with GCC Clause 44, and the following information regarding coefficients does not apply.</p> <p>The coefficients for adjustment of prices are:</p> <p>(a) For currency <i>[insert name of currency]</i>:</p> <p style="padding-left: 40px;">(i) <i>[insert percentage]</i> percent non adjustable element (coefficient A).</p> <p style="padding-left: 40px;">(ii) <i>[insert percentage]</i> percent adjustable element (coefficient B).</p> <p>(b) For currency <i>[insert name of currency]</i>:</p>

	<p>(i) <i>[insert percentage]</i> percent non adjustable element (coefficient A).</p> <p>(ii) <i>[insert percentage]</i> percent adjustable element (coefficient B).</p> <p>The Index I for local currency shall be <i>[insert index]</i>.</p> <p>The Index I for the specified international currency shall be <i>[insert index]</i>.</p> <p><i>[These proxy indices shall be proposed by the Contractor, subject to acceptance by the Employer]</i></p> <p>The Index I for currencies other than the local currency and the specified international currency shall be <i>[insert index]</i>.</p> <p><i>[These proxy indices shall be proposed by the Contractor, subject to acceptance by the Employer.]</i></p>
GCC 45.1	The proportion of payments retained is: 10%
GCC 46.1	<p>The liquidated damages for the whole of the Works are Rs 1000 per day.</p> <p>The maximum amount of liquidated damages for the whole of the Works is Rs 1.0M</p> <p><i>[Usually liquidated damages are set between 0.05 percent and 0.10 percent per day, and the total amount is not to exceed between 5 percent and 10 percent of the Contract Price. Alternatively, the daily rate could reflect the actual prejudice that the procuring entity may claim to suffer as direct cost, where applicable or a nominal value taking into consideration the size of the building, nature of construction and the incidence due to non-availability of the building as from the intended completion date. If Sectional Completion and Damages per Section have been agreed, the latter should be specified here.]</i></p>
GCC 49.1	The Performance Security amount is 10%
E. Finishing the Contract	
GCC 57.2 (g)	The maximum number of days is: 100 days
GCC 59.1	The percentage to apply to the value of the work not completed, representing the Employer's additional cost for completing the Works, is 10%

Section VIII - Contract Forms

This Section contains forms which, once completed, will form part of the Contract. The forms for Performance Security and Advance Payment Security, when required, shall only be completed by the successful Bidder after contract award.

Table of Forms

Letter of Acceptance	51
Contract Agreement.....	52
Performance Security	54
Form for Preference Security.....	57
Advance Payment Security	56

Letter of Acceptance

[on letterhead paper of the Employer]

..... *[date]*

To: *[name and address of the Contractor]*

Subject: *[Notification of Award Contract No.]*

This is to notify you that your Bid dated *[insert date]* for execution of the
.....*[insert name of the contract and identification number, as given in the Appendix to Bid]* .
..... for the Accepted Contract Amount of the equivalent of*[insert amount in numbers and words and name of currency]*, as corrected and modified in accordance with the Instructions to Bidders is hereby accepted by *(insert name of Public Body)*.

You are requested to furnish the Performance Security within 21 days in accordance with the General Conditions of Contract, using for that purpose of the Performance Security Form included in Section VI (Contract Forms) of the Bidding Document.

Authorized Signature:

Name and Title of Signatory:

Name of Agency:

Attachment: Contract Agreement

Contract Agreement

THIS AGREEMENT made theday of,, between*[name of the Employer]*. (hereinafter “the Employer”), of the one part, and*[name of the Contractor]*.(hereinafter “the Contractor”), of the other part:

WHEREAS the Employer desires that the Works known as*[name of the Contract]*.should be executed by the Contractor, and has accepted a Bid by the Contractor for the execution and completion of these Works and the remedying of any defects therein,

The Employer and the Contractor agree as follows:

1. In this Agreement words and expressions shall have the same meanings as are respectively assigned to them in the Contract documents referred to.
2. The following documents shall be deemed to form and be read and construed as part of this Agreement. This Agreement shall prevail over all other Contract documents.
 - (a) the Letter of Acceptance
 - (b) the Bid
 - (c) the Addenda Nos*[insert addenda numbers if any]*.
 - (d) the Appendix to the General Conditions of Contract
 - (e) the General Conditions of Contract;
 - (f) the Specification
 - (g) the Drawings; and
 - (h) the completed Schedules,
3. In consideration of the payments to be made by the Employer to the Contractor as indicated in this Agreement, the Contractor hereby covenants with the Employer to execute the Works and to remedy defects therein in conformity in all respects with the provisions of the Contract.
4. The Employer hereby covenants to pay the Contractor in consideration of the execution and completion of the Works and the remedying of defects therein, the Contract Price or such other sum as may become payable under the provisions of the Contract at the times and in the manner prescribed by the Contract.

IN WITNESS whereof the parties hereto have caused this Agreement to be executed in accordance with the laws of Mauritius on the day, month and year indicated above.

Signed by:
for and on behalf of the Employer

Signed by:
for and on behalf the Contractor

in the
presence of:
Witness, Name, Signature, Address, Date

in the
presence of:
Witness, Name, Signature, Address, Date

Performance Security

.....*Bank's Name and Address of Issuing Branch or Office*.....

Beneficiary:*Name and Address of Public Body*.....

Date.....

PERFORMANCE GUARANTEE No.:.....

We have been informed that*name of the Contractor*.....
(hereinafter called "the Contractor") has entered into Contract No.....*reference number of the Contract*..... dated..... with you, for the execution of *name of Contract and brief description of Works*(hereinafter called "the Contract").

Furthermore, we understand that, according to the conditions of the Contract, a performance security is required.

At the request of the Contractor, we *name of Bank*hereby irrevocably undertake to pay you any sum or sums not exceeding in total an amount of *amount in figures (amount in words)*..... such sum being payable in the types and proportions of currencies in which the Contract Price is payable, upon receipt by us of your first demand in writing accompanied by a written statement stating that the Contractor is in breach of its obligation(s) under the Contract, without your needing to prove or to show grounds for your demand or the sum specified therein.

This guarantee shall expire not later than twenty-eight days from the date of issuance of the Certificate of Completion/Acceptance Certificate, calculated based on a copy of such Certificate which shall be provided to us, or on the.....day of,, whichever occurs first. Consequently, any demand for payment under this guarantee must be received by us at this office on or before that date.

.....**Seal of bank and**

Signature(s).....

Sample Form of Preference Security

**Form of Preference Security
(Bank Guarantee)**

To: _____ [*name of
Employer*]
 _____ [*address of
Employer*]

WHEREAS _____ [*name and
addresses of the contractor*] (hereinafter called "the Contractor"), has undertaken in
 pursuance to Contract No. _____ dated _____ to execute
 _____ [*name of Contract and brief Description of
Works*], (hereinafter called "the Contract");

AND WHEREAS it has been stipulated by you in the said Contract that the
 Contractor shall furnish you with a Bank Guarantee by a local commercial bank for the
 sum specified therein as security for compliance with his obligation stated in Sub-Clause
 49.2 of the Conditions of Contract;

AND WHEREAS we have agreed to give the Contractor such a Bank Guarantee;

NOW THEREFORE we hereby affirm that we are the Guarantor and responsible
 to you, on behalf of the Contractor, up to a total of _____ [*amount
of Guarantee*]¹², we undertake to pay you, upon your first written demand and without
 your having to substantiate such demand any sum within the limit of
 _____ [*amount of Guarantee*].¹

We hereby waive the necessity of demanding the said debt from the Contractor
 before presenting us with the demand.

We further agree that no change or addition to or other modification of the terms
 of the Contract or of the Works to be performed thereunder or of any of the Contract
 documents which may be made between you and the Contractor shall in anyway release
 us from liability under this guarantee, and we hereby waive notice of any such change,
 addition or modification.

This guarantee is valid until the date of the Completion Certificate.

Signature and Seal of the Guarantor

Name of Bank _____
 Address _____

Date _____

¹² Amount to be inserted by the Guarantor in accordance with Sub-Clause 49.2 of the General Conditions of Contract

Advance Payment Security

[Bank's Name, and Address of Issuing Branch or Office]

Beneficiary: *[Name and Address of Employer]*

Date:

Advance Payment Guarantee No.:

We have been informed that *[name of the Contractor]*. (hereinafter called “the Contractor”) has entered into Contract No. *[reference number of the Contract]*. dated with you, for the execution of *[name of contract and brief description of Works]*. (hereinafter called “the Contract”).

Furthermore, we understand that, according to the Conditions of the Contract, an advance payment in the sum *[name of the currency and amount in figures]*¹. (. *[amount in words]*.) is to be made against an advance payment guarantee.

At the request of the Contractor, we *[name of the Bank]*. hereby irrevocably undertake to pay you any sum or sums not exceeding in total an amount of *[name of the currency and amount in figures]**. (. *[amount in words]*.) upon receipt by us of your first demand in writing accompanied by a written statement stating that the Contractor is in breach of its obligation under the Contract because the Contractor used the advance payment for purposes other than the costs of mobilization in respect of the Works.

It is a condition for any claim and payment under this guarantee to be made that the advance payment referred to above must have been received by the Contractor on its account number *[Contractor's account number]*. at *[name and address of the Bank]*.

The maximum amount of this guarantee shall be progressively reduced by the amount of the advance payment repaid by the Contractor as indicated in copies of interim statements or payment certificates which shall be presented to us. This guarantee shall expire, at the latest, upon our receipt of a copy of the interim payment certificate indicating that eighty (80) percent of the Contract Price has been certified for payment, or on the . . . day of ,², whichever is earlier. Consequently, any demand for payment under this guarantee must be received by us at this office on or before that date.

. *[Seal of Bank and Signature(s)]*.

Note –

All italicized text is for guidance on how to prepare this demand guarantee and shall be deleted from the final document.

1 The Guarantor shall insert an amount representing the amount of the advance payment denominated either in the currency(ies) of the advance payment as specified in the Contract, or in a freely convertible currency acceptable to the Employer.

2 Insert the expected expiration date of the Time for Completion. The Employer should note that in the event of an extension of the time for completion of the Contract, the Employer would need to request an

extension of this guarantee from the Guarantor. Such request must be in writing and must be made prior to the expiration date established in the guarantee. In preparing this guarantee, the Employer might consider adding the following text to the form, at the end of the penultimate paragraph: “The Guarantor agrees to a one-time extension of this guarantee for a period not to exceed [six months][one year], in response to the Employer’s written request for such extension, such request to be presented to the Guarantor before the expiry of the guarantee.